

3-73-**17**-0.1  
3-73-**17**-1.1  
5-73-**17**-0.1  
5-73-**17**-1.1

**joulia**<sup>®</sup>  
SWITZERLAND

**DE** Duschrinne mit Wärmetauscher  
**FR** Rigole de douche avec échangeur thermique  
**EN** Shower drain channel with heat exchanger  
**NL** Douchegoot met warmtewisselaar

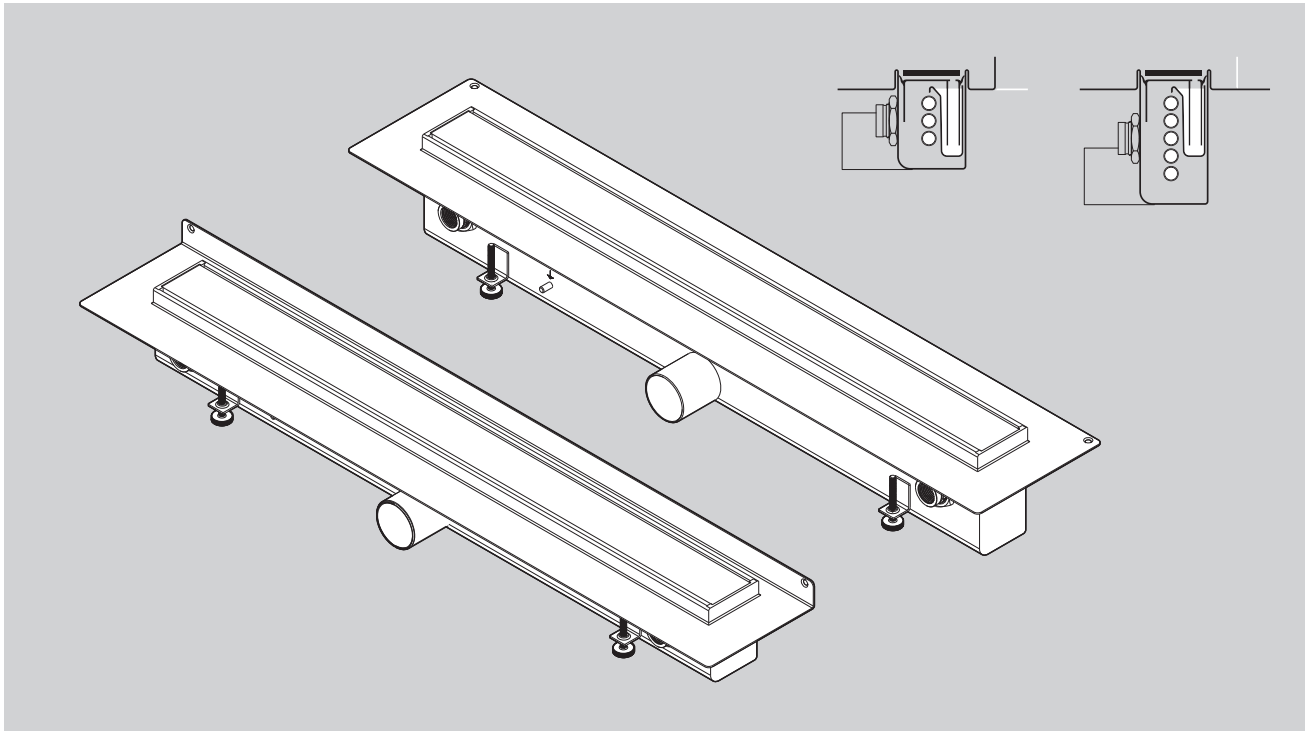

Montage- und Betriebsanleitung.  
Notice de montage et de mise en service.  
Installation and operating instructions.  
Montage- en gebruikshandleiding.

**kiwa** 

 **SVGW**

 **WRAS**  
APPROVED PRODUCT

 **DVGW**



Ersatzteile > **Seite 23**  
Pièces de rechange > **page 23**  
Spare parts > **page 23**  
Vervangingsonderdelen > **pagina 23**

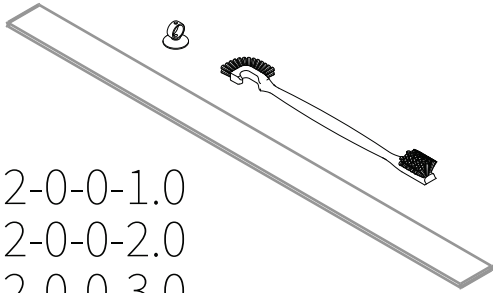

2-0-0-1.0  
2-0-0-2.0  
2-0-0-3.0  
2-0-0-4.0

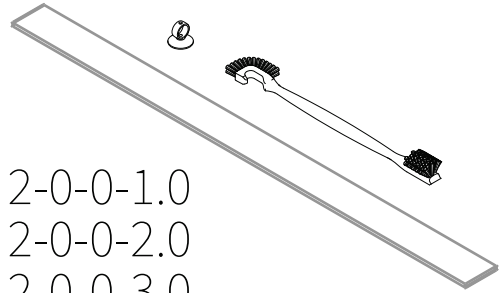

2-0-0-1.0  
2-0-0-2.0  
2-0-0-3.0  
2-0-0-4.0

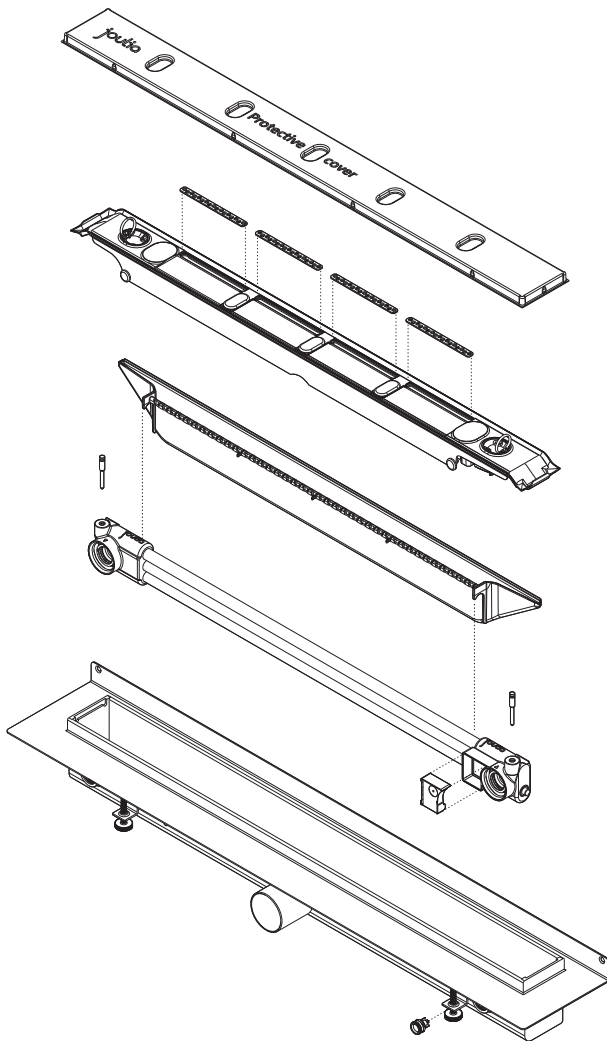

3-73-17-1.1

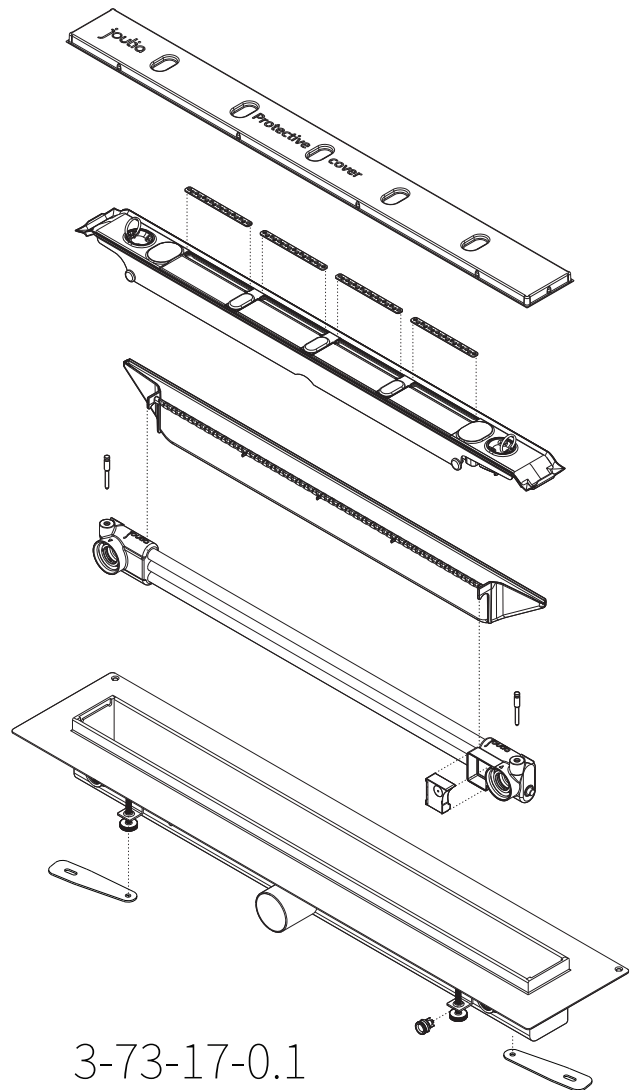

3-73-17-0.1



Ersatzteile > **Seite 23**  
Pièces de rechange > **page 23**  
Spare parts > **page 23**  
Vervangingsonderdelen > **pagina 23**

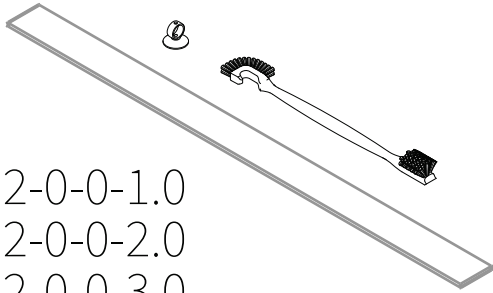

2-0-0-1.0  
2-0-0-2.0  
2-0-0-3.0  
2-0-0-4.0

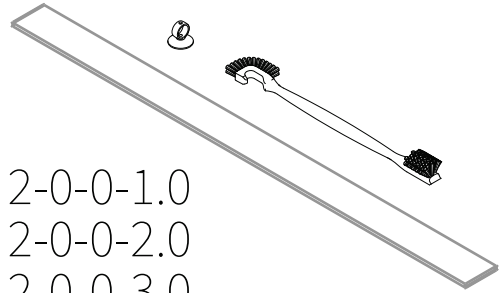

2-0-0-1.0  
2-0-0-2.0  
2-0-0-3.0  
2-0-0-4.0

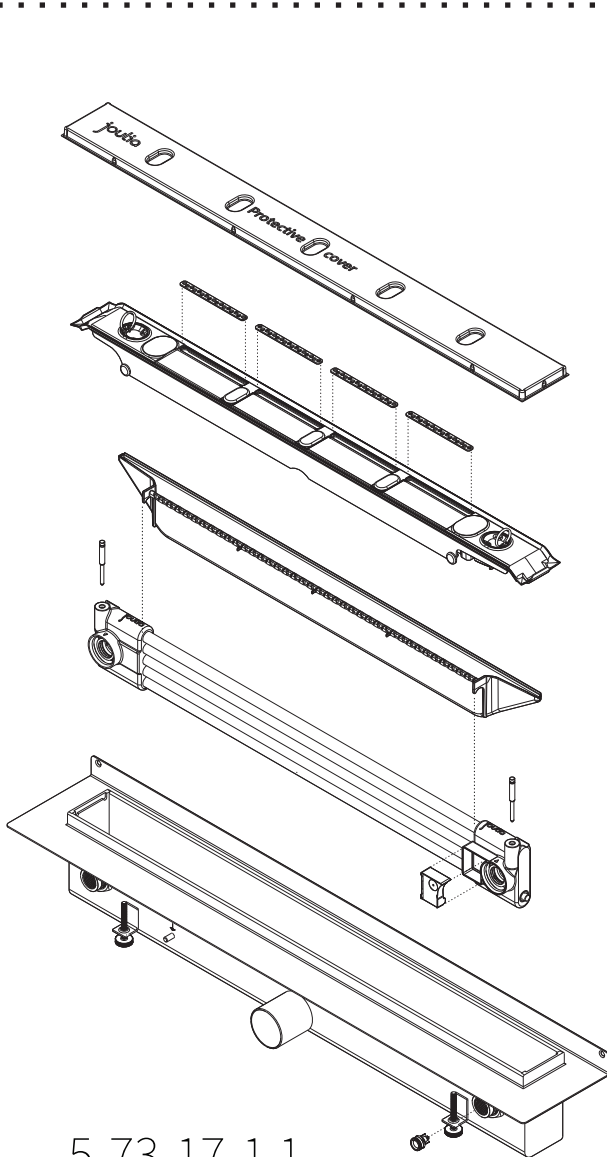

5-73-17-1.1

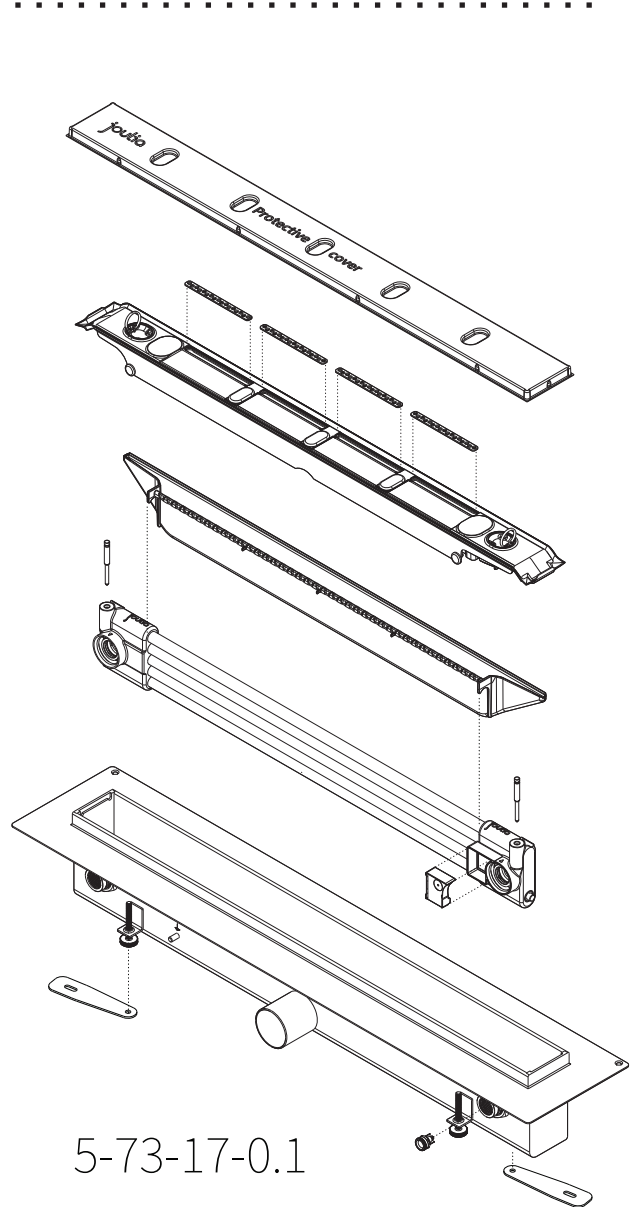

5-73-17-0.1

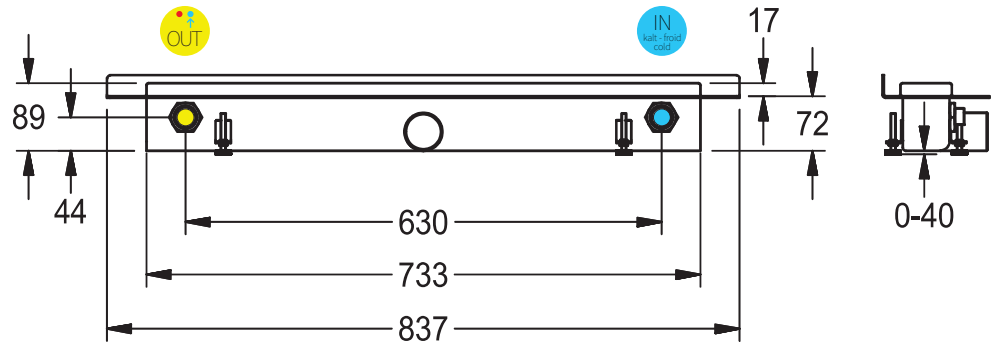

3-73-17-1.1

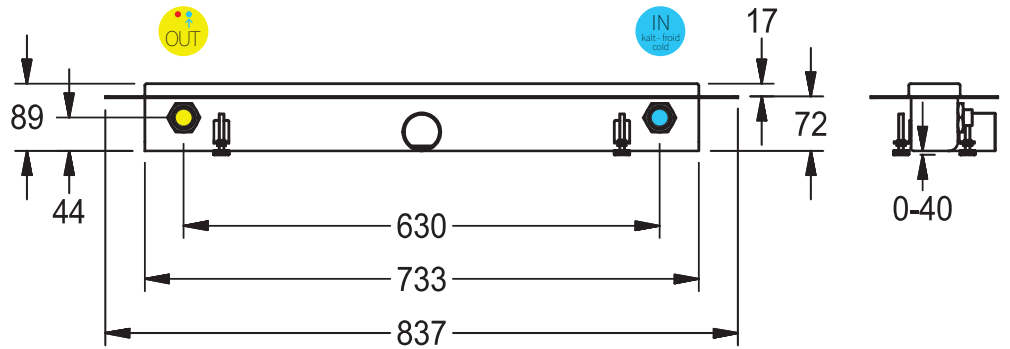
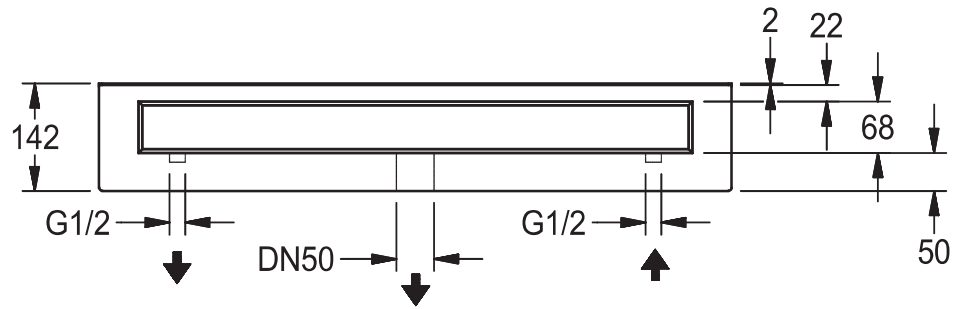

3-73-17-0.1

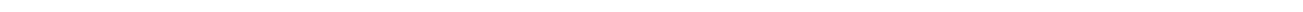
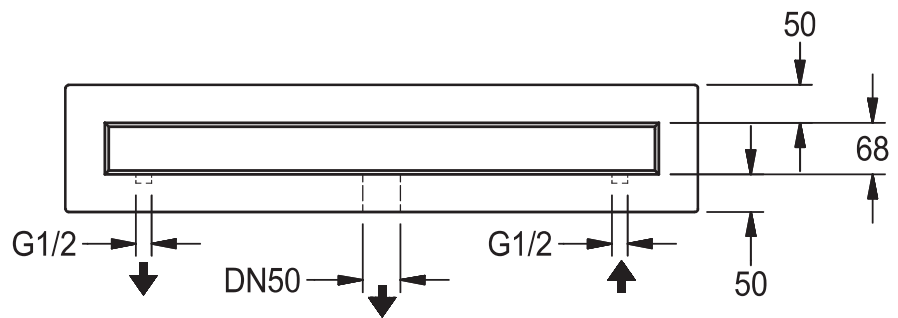

2-0-0-1.0  
2-0-0-2.0  
2-0-0-3.0

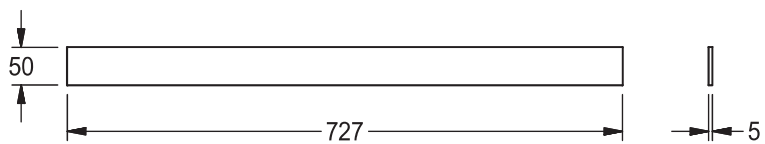

2-0-0-4.0

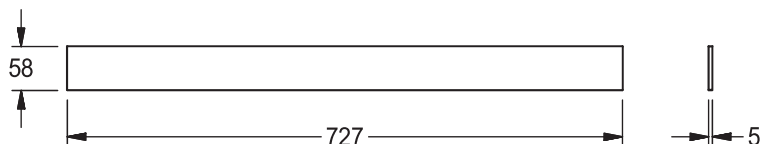

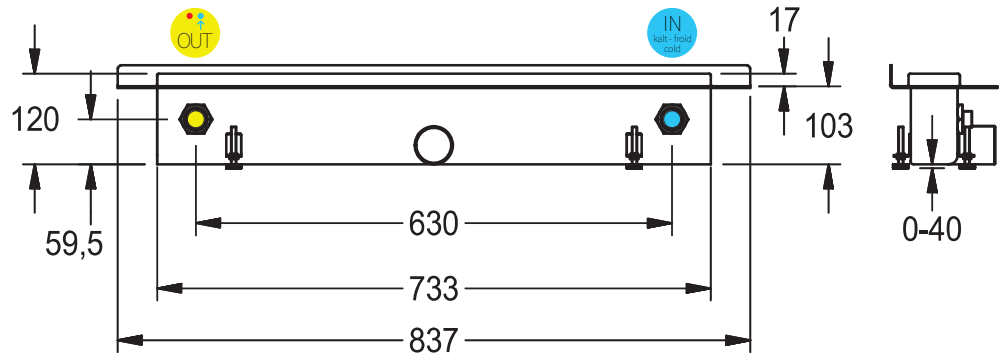

5-73-17-1.1

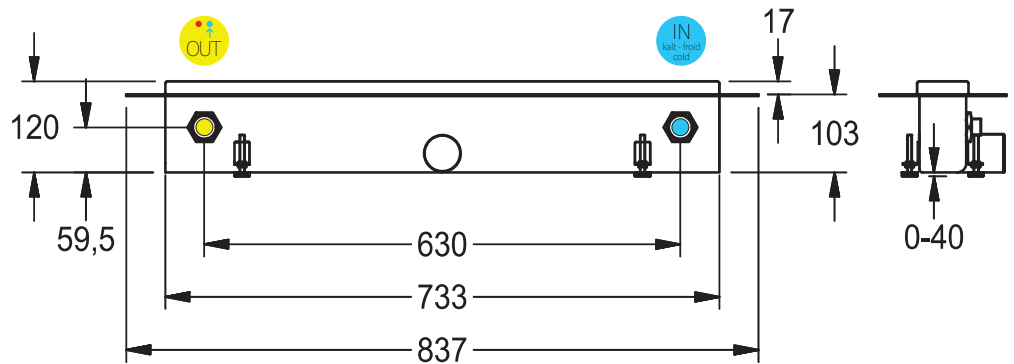
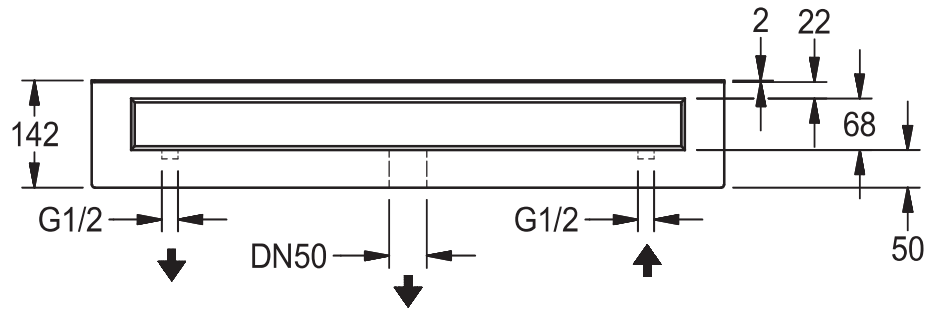

5-73-17-0.1

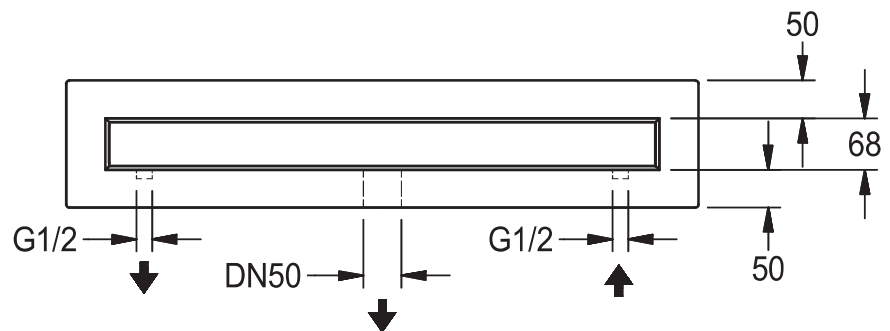

2-0-0-1.0

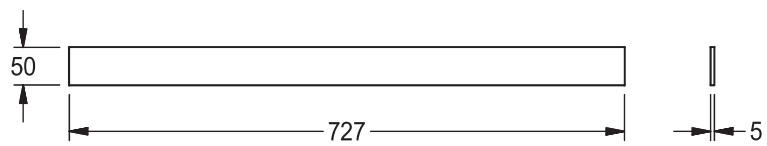

2-0-0-2.0

2-0-0-3.0

2-0-0-4.0

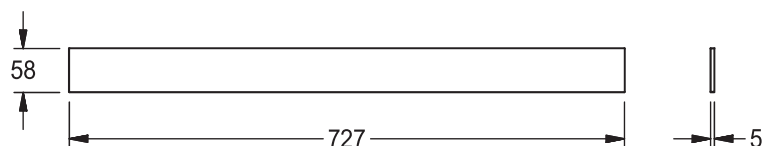



3-73-17-1.1

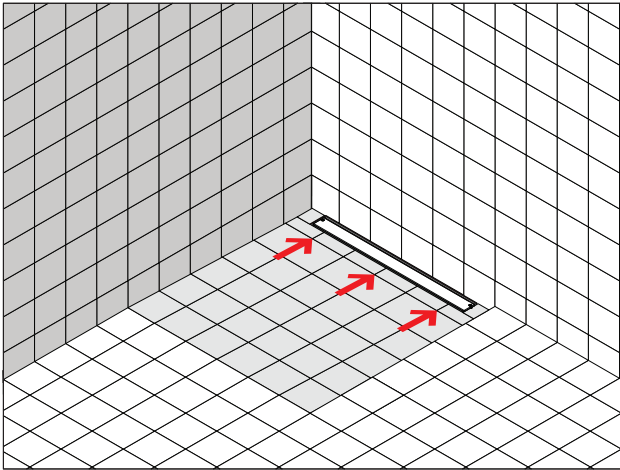
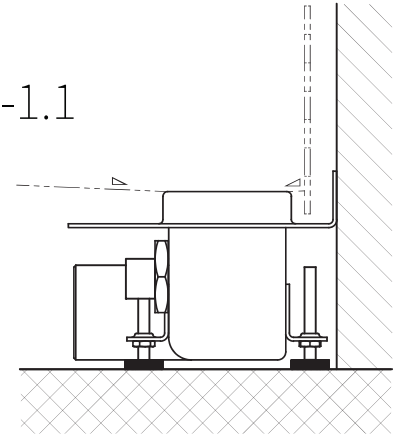

5-73-17-1.1

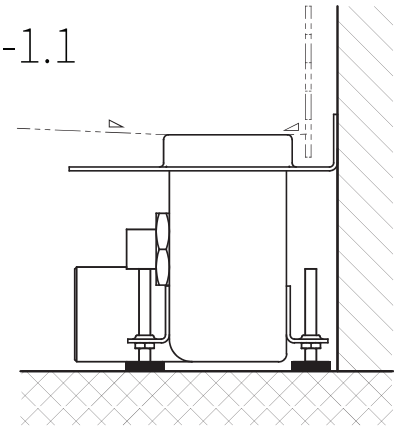

3-73-17-0.1

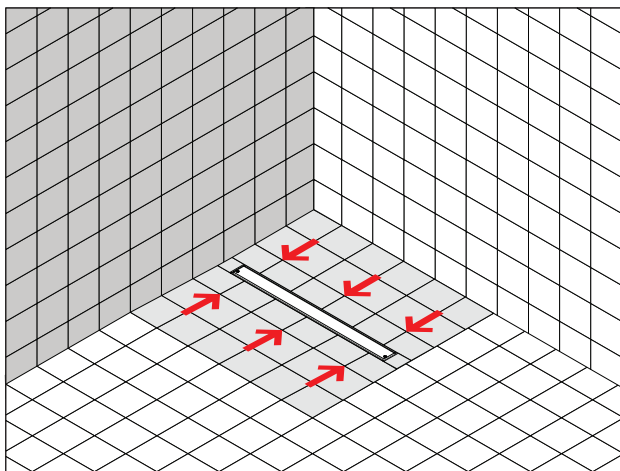
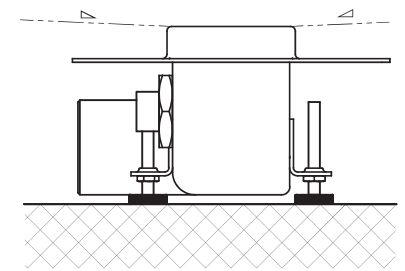

5-73-17-0.1

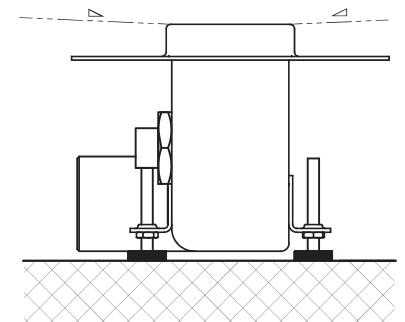



DE

## Montage- und Betriebsanleitung

### Wichtige Hinweise

Nach NEN 1006 dürfen in einem Trinkwassersystem nur Teile und Komponenten verwendet werden, die nach den anerkannten Regeln der Technik hergestellt wurden.

### Qualitätszeichen einer anerkannten technischen Überwachungsstelle

So zeigt beispielsweise das Kiwa-Wasserzeichen, dass diese Bedingung erfüllt ist. Darüber hinaus müssen die verwendeten Materialien der "Verordnung über Materialien und Chemikalien für die Trink- und Warmwasserversorgung" entsprechen.

Der Bauherr ist gesetzlich für die qualitativen Aspekte der Trinkwasserversorgung im Gebäude verantwortlich. Die gesamte Installation von der Abgabestelle (oft der Wasserzähler) liegt in seiner Verantwortung. Änderungen und Wartungen an der Anlage fallen ebenfalls unter diese Verantwortung.

Die Installation der Duschrinne mit Wärmerückgewinnung darf nur durch Fachpersonen erfolgen.

Vor Installation Rohrleitung spülen! In Abhängigkeit von der Wasserqualität, den örtlichen Gegebenheiten und den vor Ort geltenden Bestimmungen die Duschrinne in regelmäßigen Abständen prüfen und warten.

### Sicherheit und Prävention von Legionellose

Wenn sich die Dusche im Ruhezustand befindet (kein Wasserdurchfluss), sollte die Temperatur 25°C nicht überschreiten. Die Duschrinne sollte daher nicht in der Nähe von wärmeleitenden Rohren, auf heißen Oberflächen oder in Räumen installiert werden, in denen die Temperatur über einen längeren Zeitraum 25°C übersteigt. **Isolieren Sie die Duschwanne und/oder die Kaltwasserleitungen daher nicht.**

### Dieses Produkt enthält Bauteile aus Kupfer

Gemäss deutschem Kupferinstitut (DIN 50930-6) können Kupferrohre und Fittings aus Kupfer bzw. Kupferlegierungen uneingeschränkt für Trinkwasser verwendet werden wenn der pH-Wert pH 7,4 oder höher ist oder wenn bei pH-Werten zwischen pH 7,0 und pH 7,4 der TOC-Wert 1,5 mg/L(g/m<sup>3</sup>) nicht überschreitet. (TOC = Gesamtmenge an organischem Kohlenstoff)

### Technische Daten

- Mindestfließdruck: 1,0 bar
- Maximaler Betriebsdruck: 10 bar
- Empfohlener Fließdruck: 3 bar
- Ablaufleistung: 0,8 l/s
- Sperrwasserhöhe: 50 mm
- Belastungsklasse: K3 (max. 300 kg)
- Kaltwasservolumen im Wärmetauscher:  
3P: 0.18 l / 5P: 0.29 l

FR

## Notice de montage et de mise en service

### Remarques importantes

Conformément à la norme NEN 1006, seules des pièces et composants fabriqués conformément à des réglementations techniques reconnues peuvent être utilisés dans un système d'eau potable.

### Label de qualité d'un organisme de contrôle reconnu

Par exemple, le filigrane de Kiwa montre que cette condition a été remplie. En outre, les matériaux utilisés doivent être conformes à la "réglementation sur les matériaux et produits chimiques pour l'alimentation en eau potable et en eau chaude sanitaire".

Le propriétaire du bâtiment est légalement responsable des aspects qualitatifs de l'approvisionnement en eau potable dans le bâtiment. L'installation complète depuis le point de livraison (souvent le compteur d'eau) est à sa charge. Les modifications et l'entretien de l'installation relèvent également de cette responsabilité.

Rincer les conduites avant d'installer ! En fonction de la qualité de l'eau, ainsi que des conditions et des dispositions locales, il convient de contrôler et d'entretenir le caniveau de douche à intervalles réguliers.

### Sécurité et prévention de la légionellose

Lorsque le receveur de douche est au repos (pas de débit d'eau d'alimentation), il faut éviter que la température ne dépasse 25°C. Le receveur de douche ne doit donc pas être installé à proximité de tuyaux conducteurs de chaleur, sur des surfaces chaudes ou dans des pièces où la température dépasse 25 °C pendant une longue période. **Ne pas isoler le receveur de douche et/ou les tuyaux d'eau froide qui s'y trouvent.**

### Ce produit contient des composants de cuivre

Selon l'institut allemand du cuivre (DIN 50930-6), les tuyaux et raccords en cuivre et en alliages de cuivre peuvent être utilisés sans restriction pour l'eau potable si la valeur pH est de 7,4 ou plus ou si à des valeurs pH comprises entre 7,0 et 7,4, la valeur COT ne dépasse pas 1,5 mg/L(g/m<sup>3</sup>) (COT= quantité totale de carbone organique)

### Données techniques

- Pression dynamique minimale: 1,0 bar
- Pression de service maximale: 10 bar
- Pression dynamique recomm.: 3 bar
- Débit d'écoulement: 0,8 l/s
- Hauteur garde d'eau: 50 mm
- Classe de résistance: K3 (max. 300 kg)
- Volume d'eau froid dans l'échangeur:  
3P: 0.18 l / 5P: 0.29 l



EN

## Installation and operating instructions

### Important notes

According to NEN 1006, only parts and components manufactured in accordance with the recognized rules of technology may be used in a drinking water system.

### Quality mark of a recognised technical inspection body

For example, the Kiwa watermark indicates that this condition is met. In addition, the materials used must comply with the "Ordinance on Materials and Chemicals for Drinking and Hot Water Supply".

The client is legally responsible for the qualitative aspects of the drinking water supply in the building. The entire installation from the point of delivery (often the water meter) is his responsibility. Changes and maintenance of the system also fall under this responsibility.

The shower drain with heat recovery may only be installed by specialists.

Before installing flush piping system! The fitting must be checked and maintained at regular intervals depending on the water quality and in accordance with the local conditions, and rules and regulations applicable at the site.

### Safety and prevention of legionellosis

When the shower is at rest (no water flow), the temperature should not exceed 25°C. The shower channel should therefore not be installed near heat-conducting pipes, on hot surfaces or in rooms where the temperature will exceed 25°C for an extended period of time.

**Therefore, do not insulate the shower tray and/or cold water lines.**

### This product contains copper components

According to the German Copper Alliance (DIN 50930-6), pipes and fittings made of copper or copper alloys can be used for potable water with no restrictions if the pH value is 7.4 or higher, or the pH value is between 7.0 and 7.4 and the total organic carbon (TOC) value does not exceed 1.5 mg/L (g/m<sup>3</sup>) (TOC = total amount of organic carbon)

### Technical data

- Minimum flow pressure: 1,0 bar
- Maximum operating pressure: 10 bar
- Recommended flow pressure: 3 bar
- Drain performance: 0,8 l/s
- Water trap: 50 mm
- Load class: K3 (max. 300 kg)
- Cold water volume in heat exchanger:  
3P: 0.18 l / 5P: 0.29 l

NL

## Montage en installatie

### Belangrijke opmerkingen

NEN 1006 geeft de eisen waaraan een leidingwaterinstallatie moet voldoen vanuit het oogpunt van volksgezondheid, veiligheid en doelmatigheid. De norm is bedoeld om te worden toegepast voor elke nieuw aan te leggen leidingwaterinstallatie en voor uitbreidingen, wijzigingen, gehele of gedeeltelijke vernieuwingen, herstellingen en onderhoud van een bestaande leidingwaterinstallatie.

### Keurmerk erkende technische keuringsinstantie

Bijvoorbeeld, Kiwa Watermark, laat zien dat aan deze voorwaarde is voldaan. Daarnaast moeten de toegepaste materialen voldoen aan de "regeling materialen en chemicaliën drink- en warm tapwatervoorziening". De gebouw eigenaar is wettelijk verantwoordelijk voor kwalitatieve aspecten van het drinkwater in het gebouw. De gehele installatie vanaf het leveringspunt (vaak de watermeter) valt onder zijn verantwoordelijkheid. Aanpassingen aan en het onderhouden van de installatie valt ook hieronder.

De douchegoot met warmteterugwinning mag alleen door specialisten worden geïnstalleerd. Voorafgaande de installatiewerkzaamheden dient de koud waterleiding gespoeld te worden. De aansluitingen dienen afhankelijk van de waterkwaliteit, lokale omstandigheden en voorschriften periodiek gecontroleerd en/of onderhouden te worden.

### Veiligheid en legionellapreventie

Voorkom dat, wanneer de douchegoot-wtw in ruststand is (geen stroming van aanvoerwater), de temperatuur hoger wordt dan 25°C. De douchegoot-wtw mag daarom niet in de buurt van warmte voerende leidingen, op warme oppervlakten of in ruimtes worden gemonteerd waar de temperatuur langdurig hoger dan 25°C. **Ook mag je de douchegoot-wtw en/of de koud waterleidingen niet isoleren.**

### Dit product bevat koperen componenten

Buizen en fittingen van koper mogen met het oog op een mogelijke overschrijding van de grenswaarden van koperionen volgens het drinkwaterbesluit alleen worden gebruikt, als de pH-waarde  $\geq 7,4$  is of als bij waarden van pH = 7,0–7,4 de totale hoeveelheid organisch koolstof TOC niet hoger is dan 1,5 mg/l. (TOC = totale hoeveelheid organische koolstof)

### Technische gegevens

- Minimaal vereiste druk: 1,0 bar
- Maximale druk: 10 bar
- Aanbevolen druk: 3 bar
- Afvoer: 0,8 l/sec
- Waterslot: 50 mm
- Drukbelastingklasse: K3 (max. 300 kg)
- Volume koud water in de warmtewisselaar:  
3P: 0.18 l / 5P: 0.29 l





Schallschutz-Set (optional)

Isolation phonique (optionnel)

Sound insulation set (optional)

Akoestisch pakket (optiioneel)

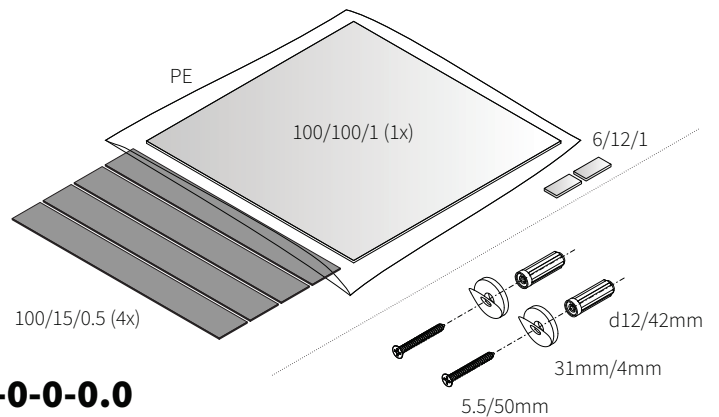

**1-0-0-0.0**



Terugslagklep type EA

**Voor installaties in Nederland**

Alvorens de Joulia douchegoot aan te sluiten, moeten een controleerbare terugslagklep van het type EA en een kogelkraan in de aanvoerende drinkwaterleiding worden geïnstalleerd.

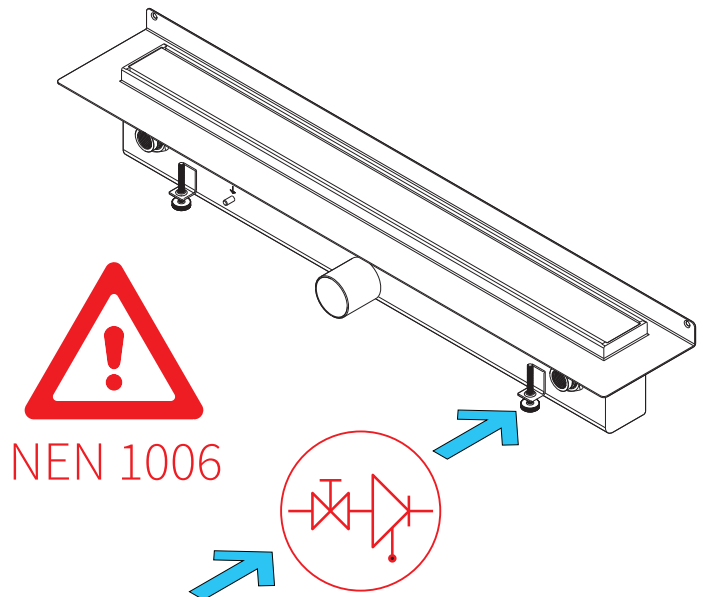

Werkzeuge & Hilfsmittel

Outils et aides

Tools & Aids

Gereedschap & hulpmiddelen

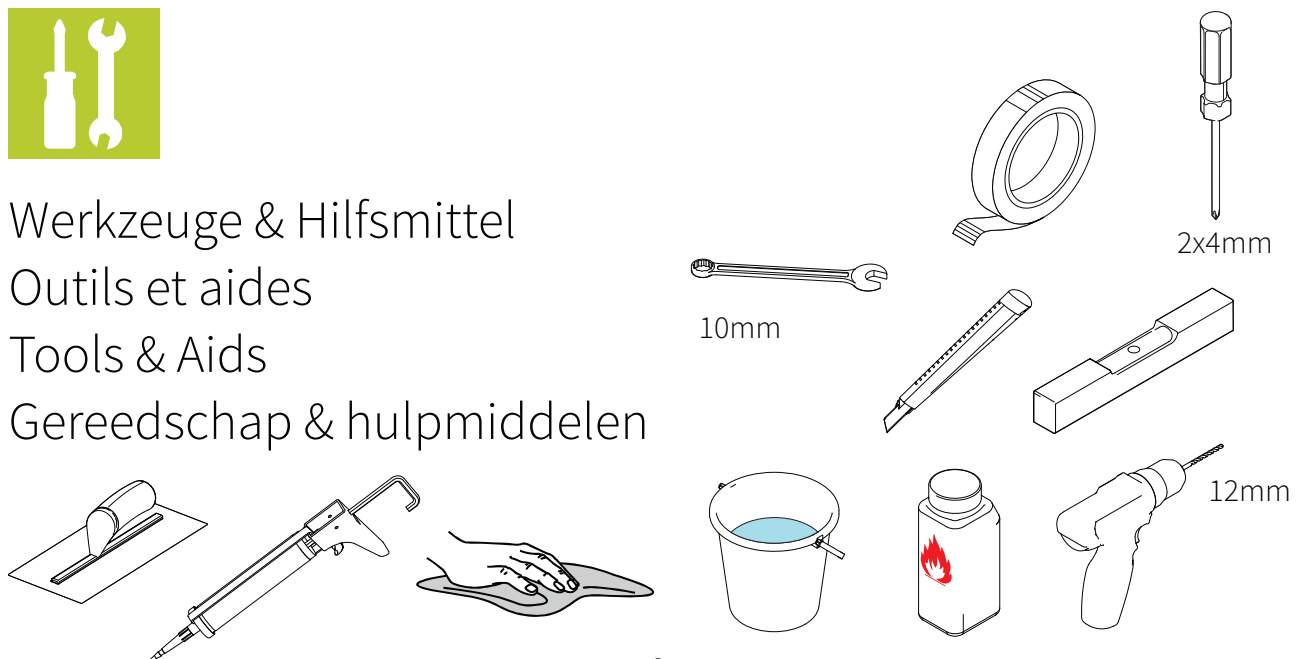

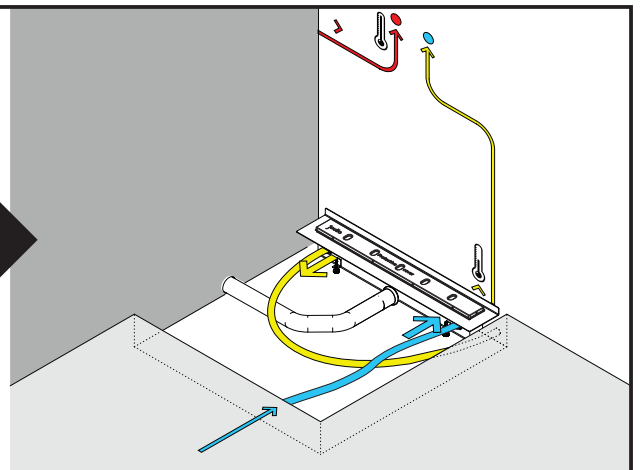
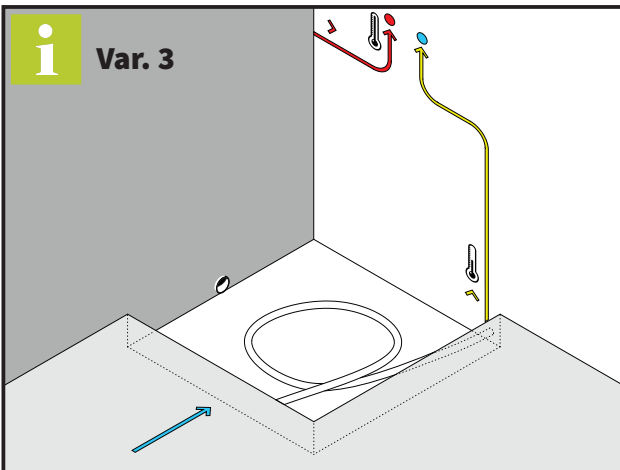
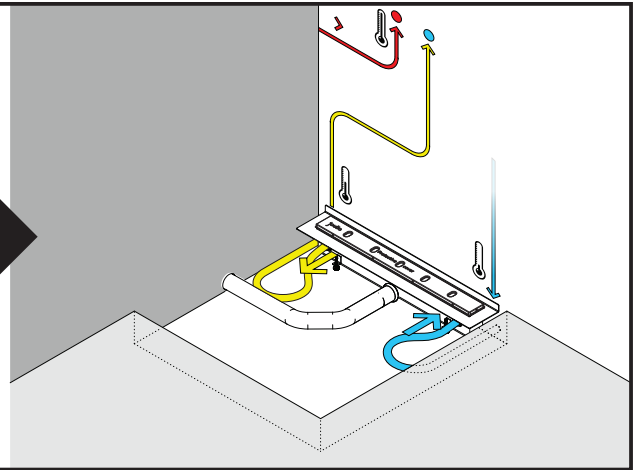
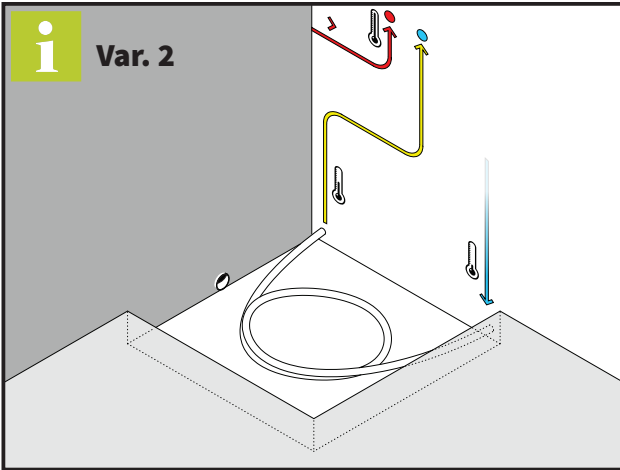
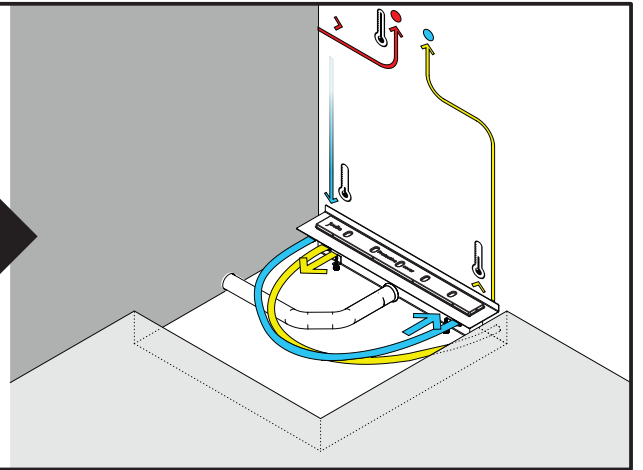
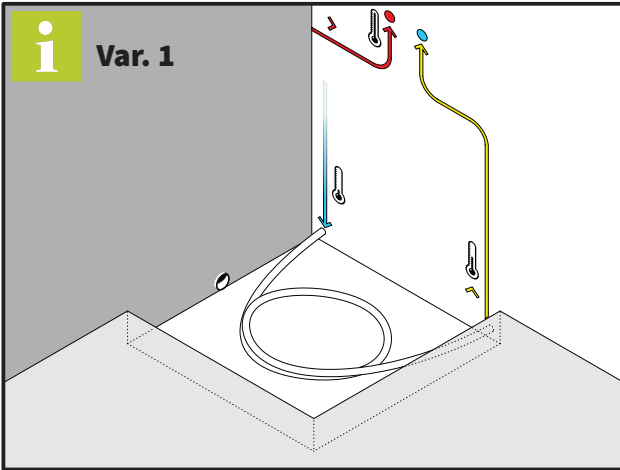
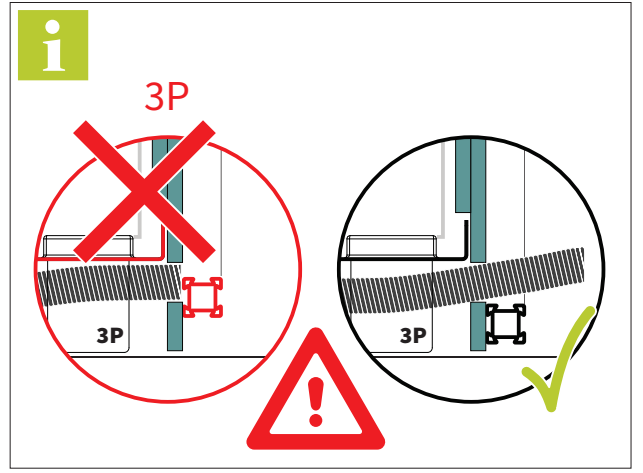
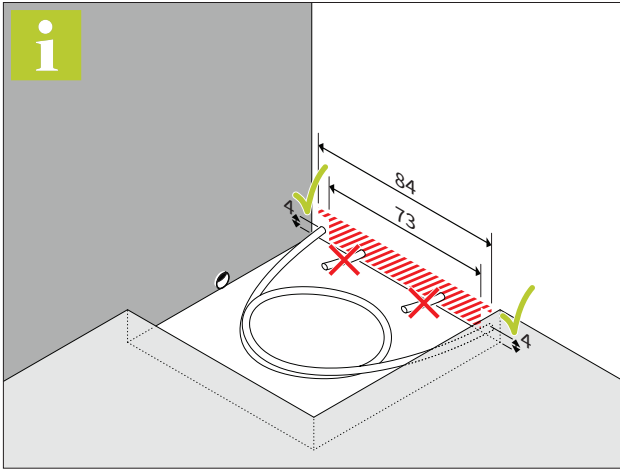

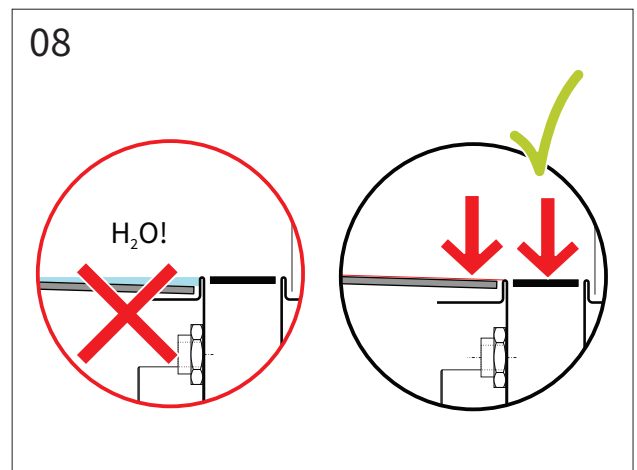
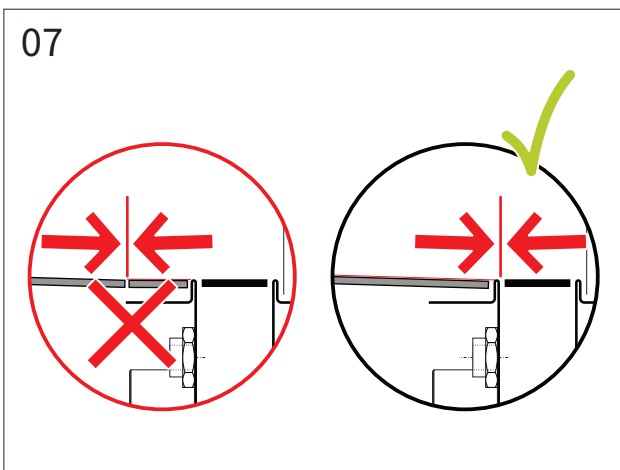
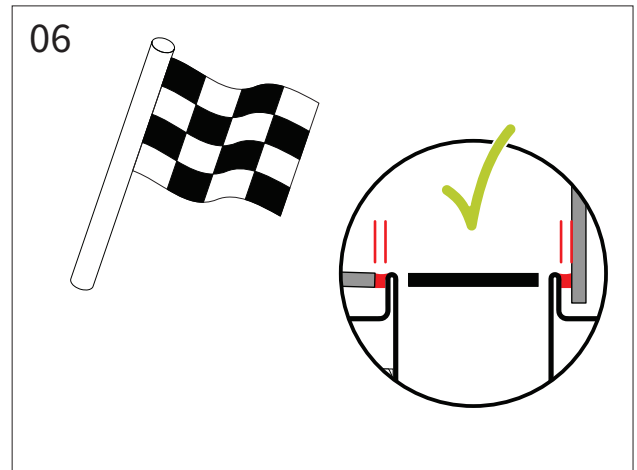
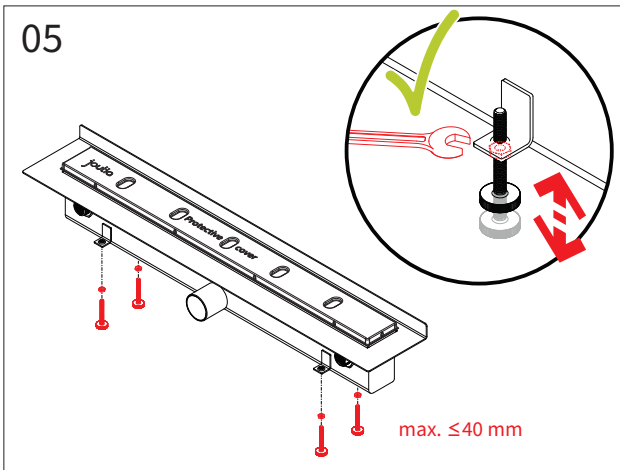
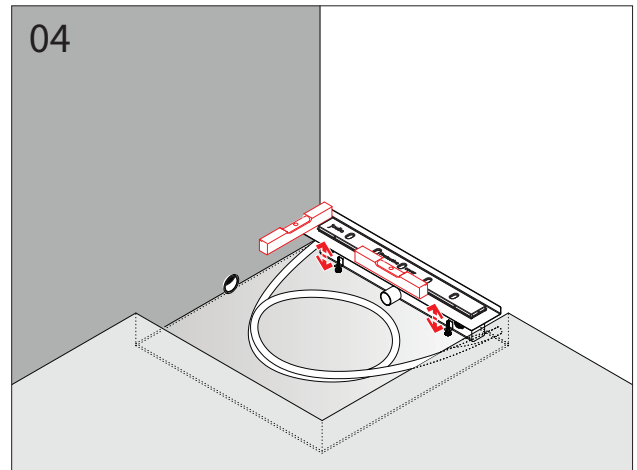
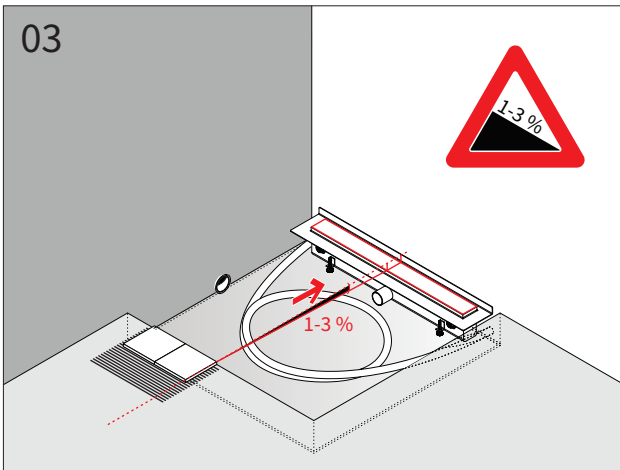
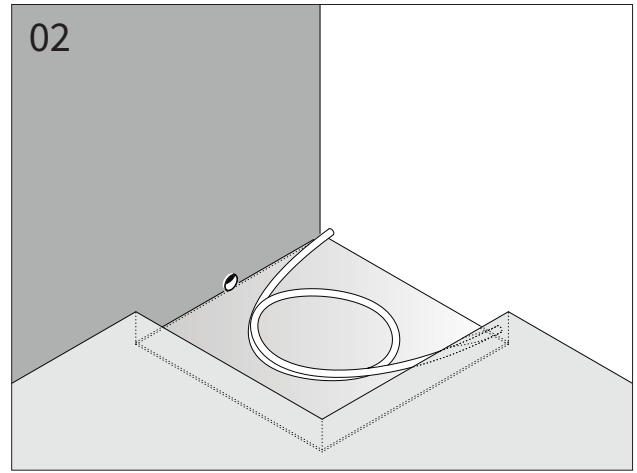
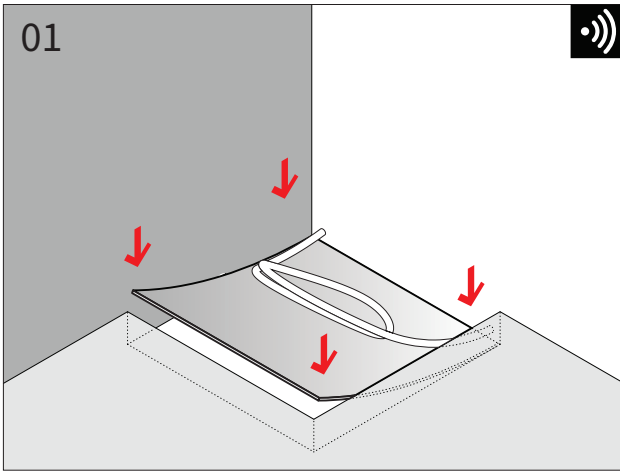

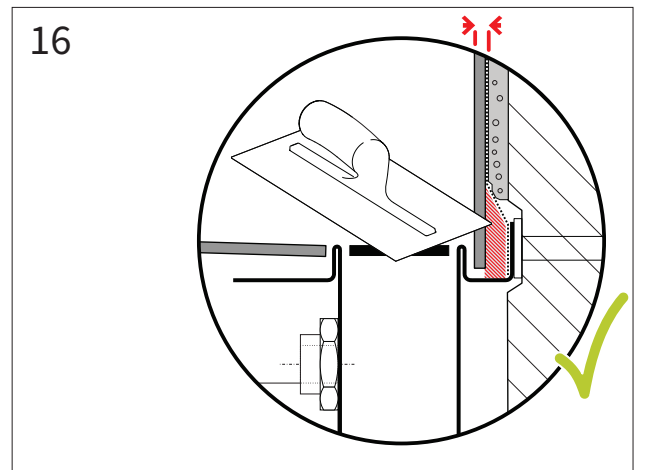
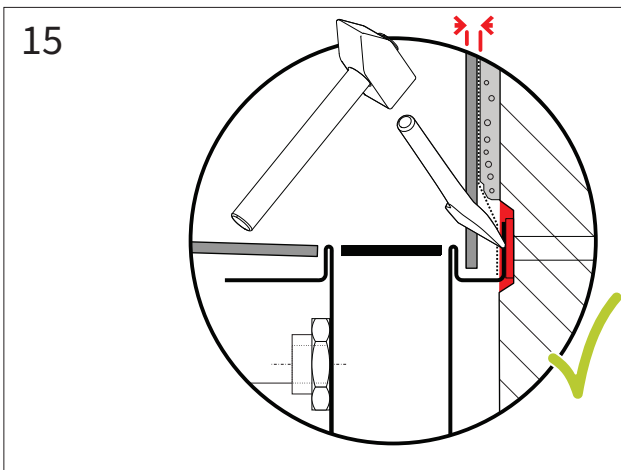
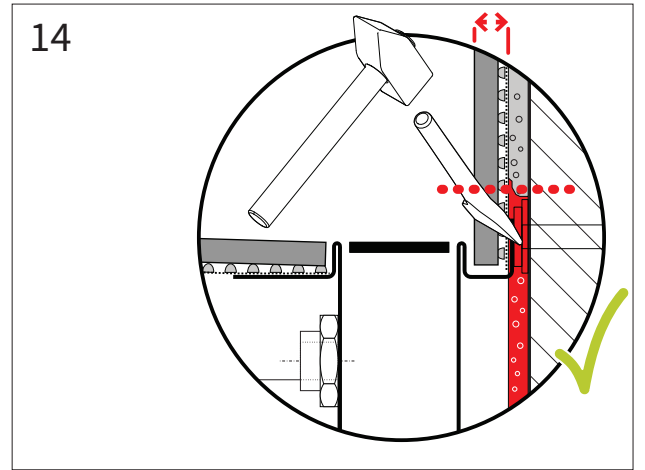
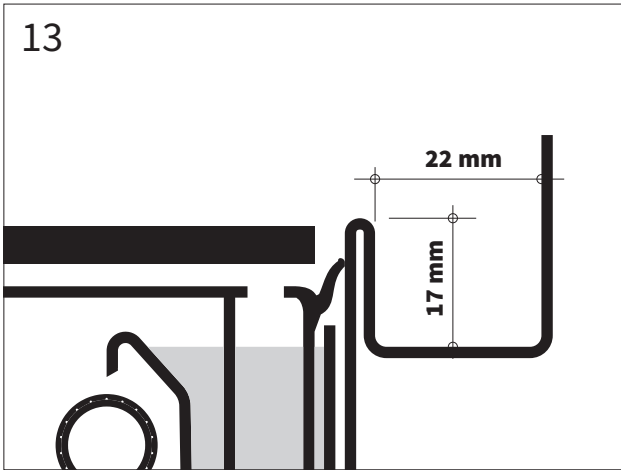
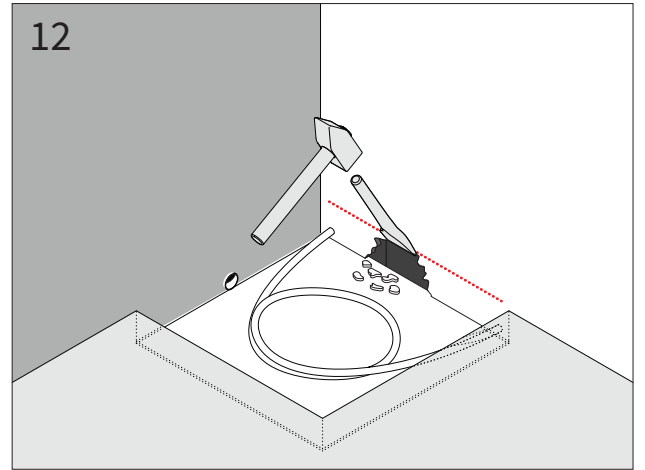
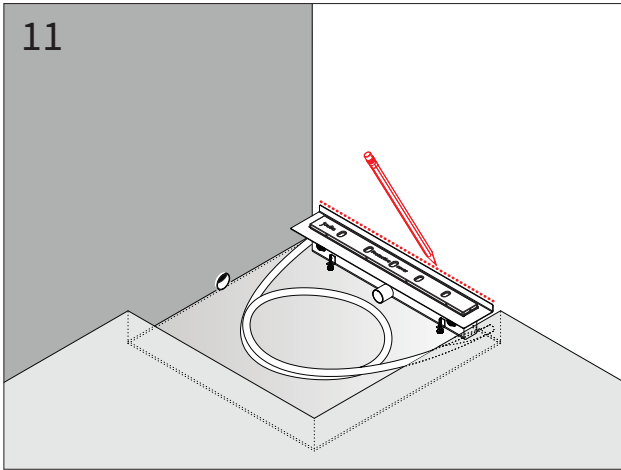
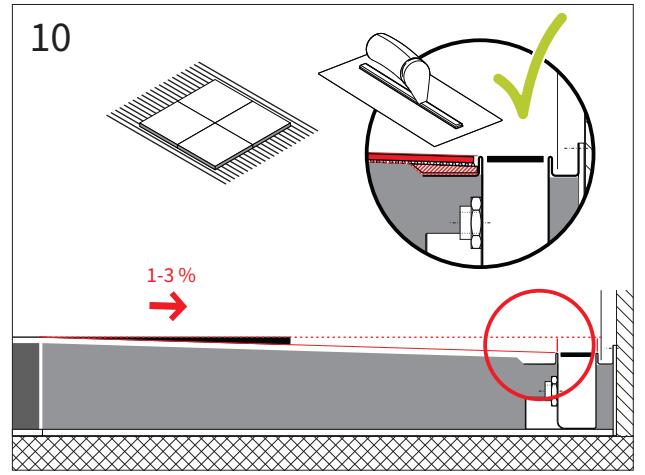
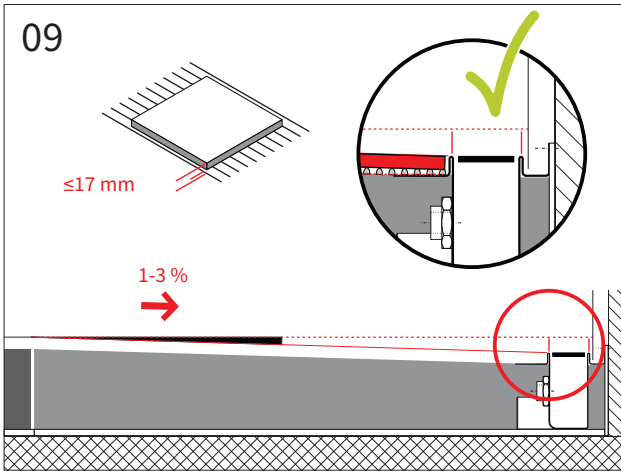

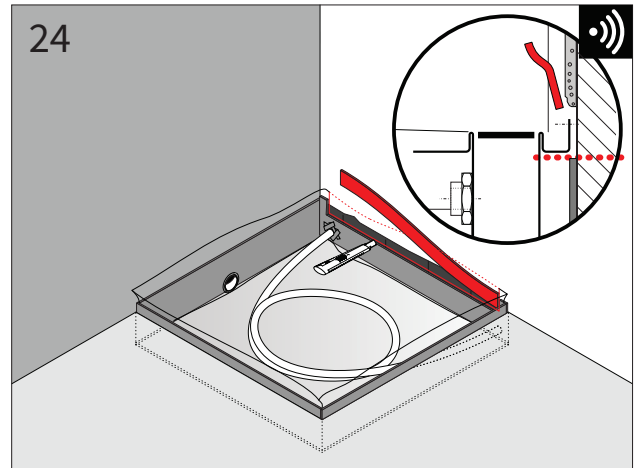
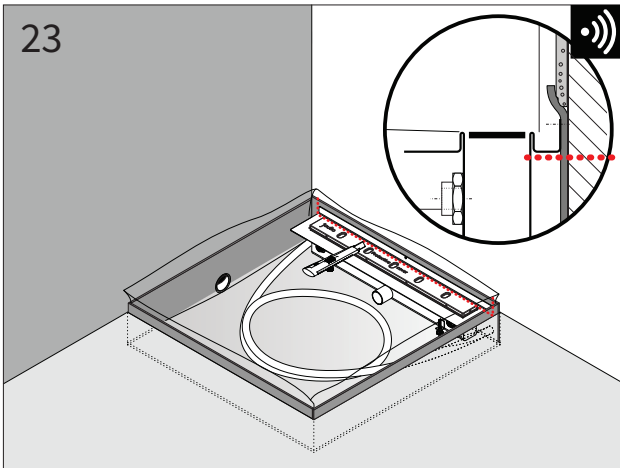
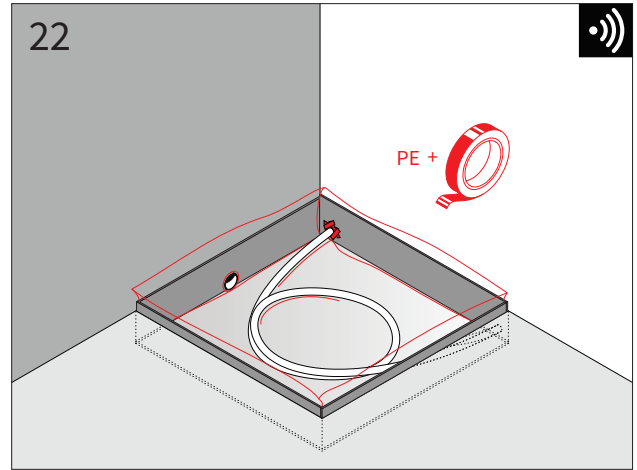
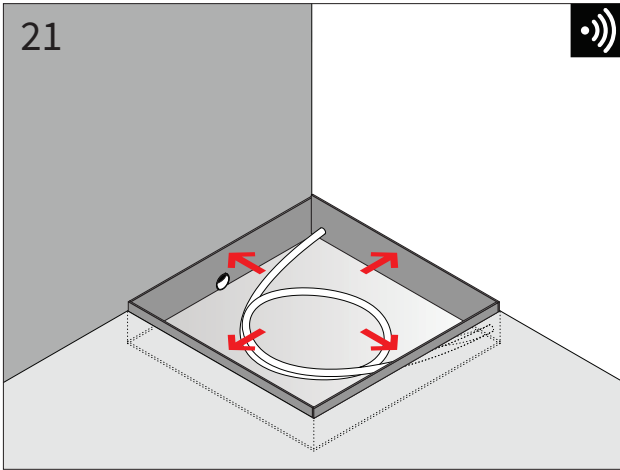
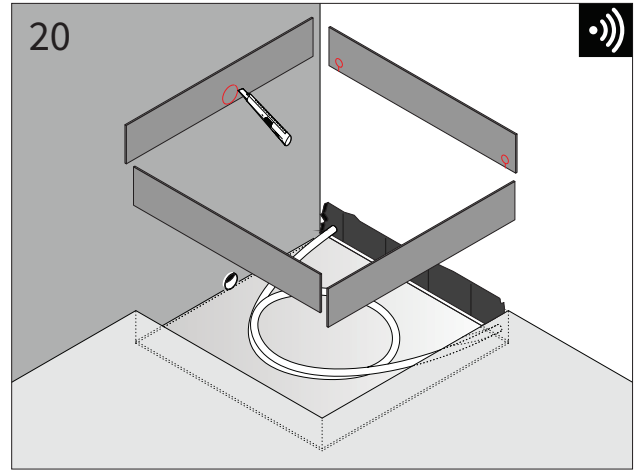
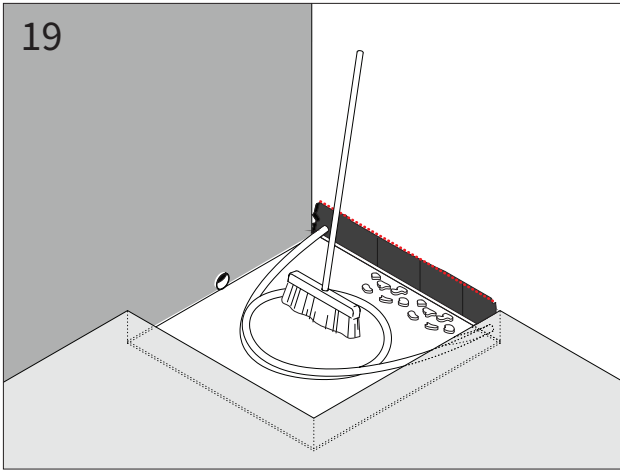
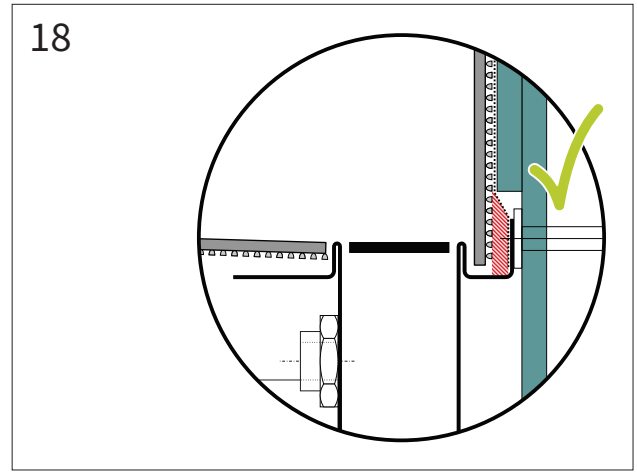
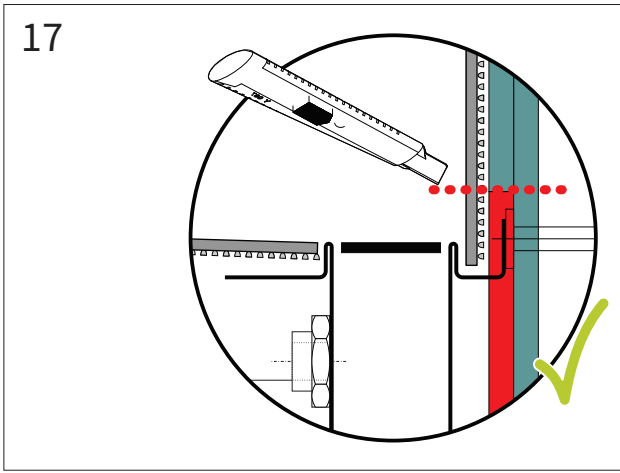

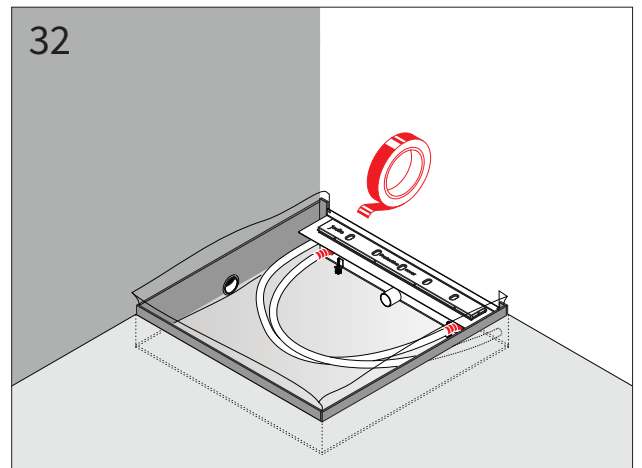
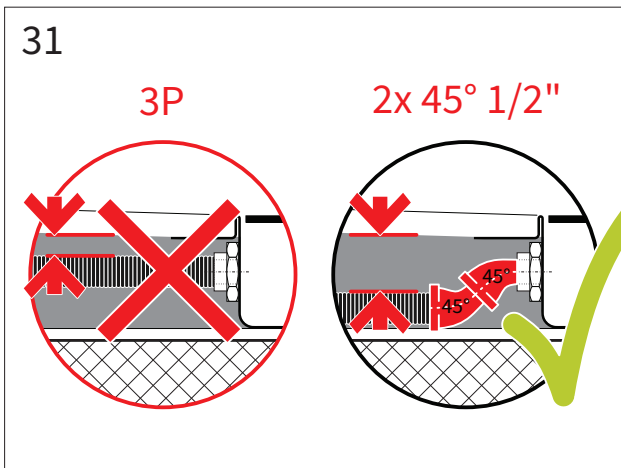
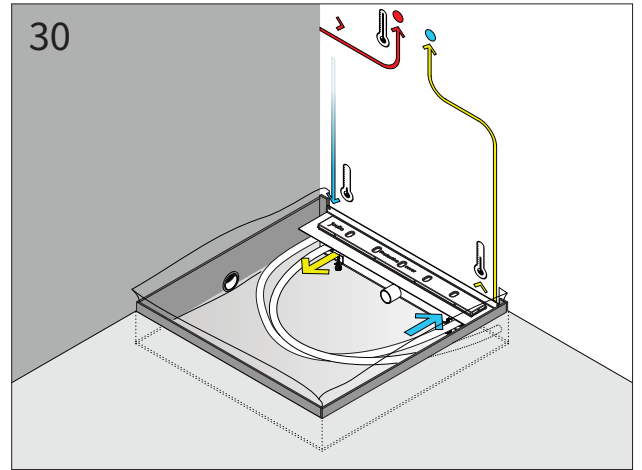
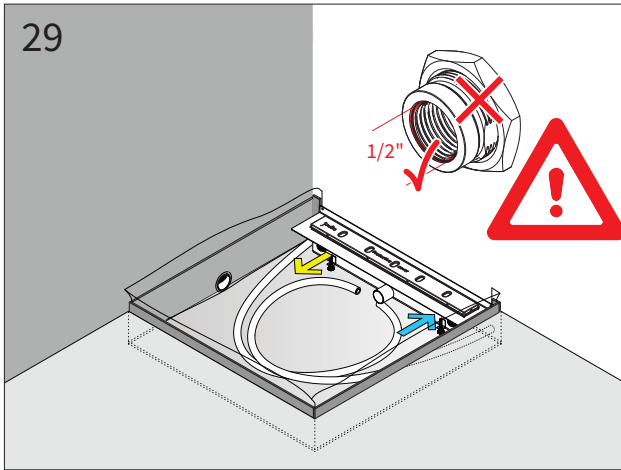
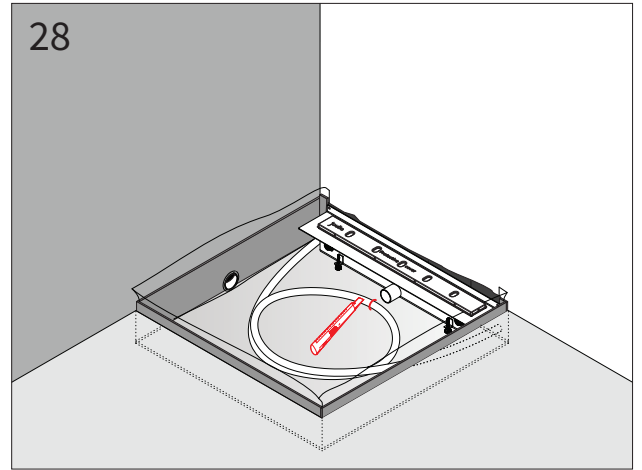
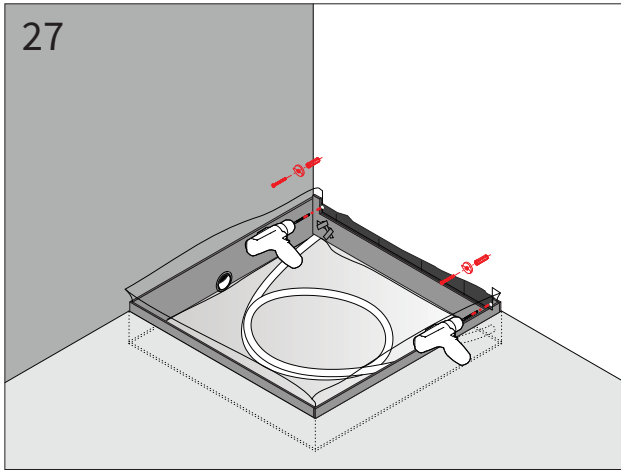
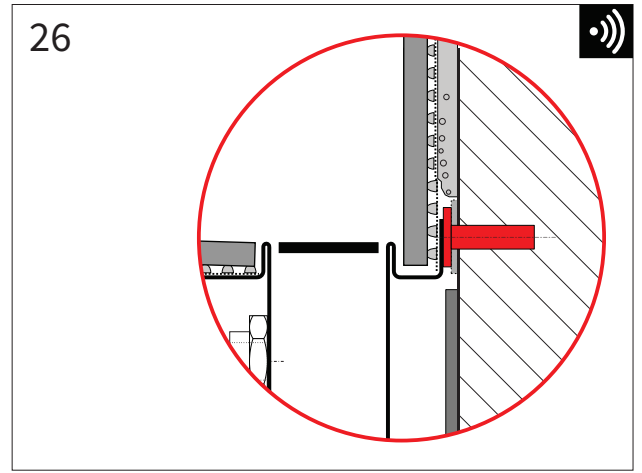
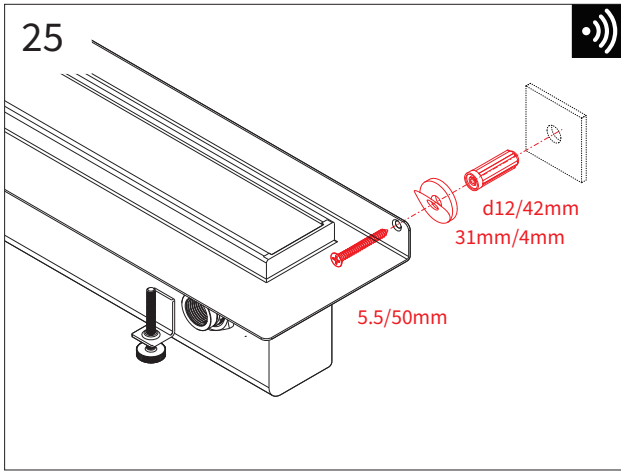

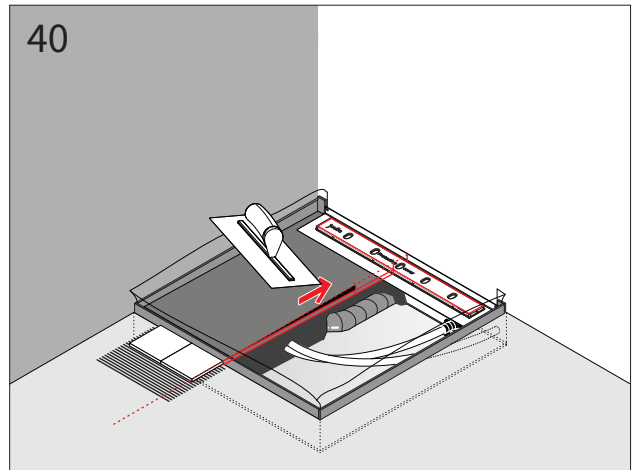
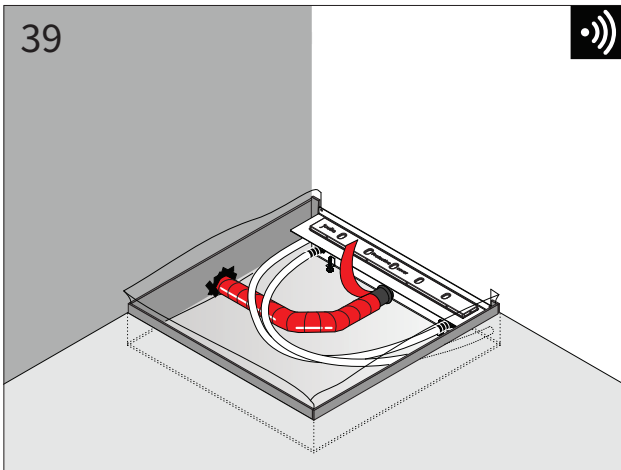
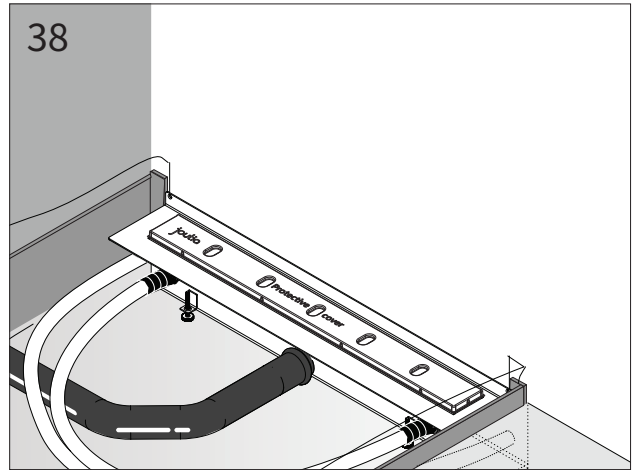
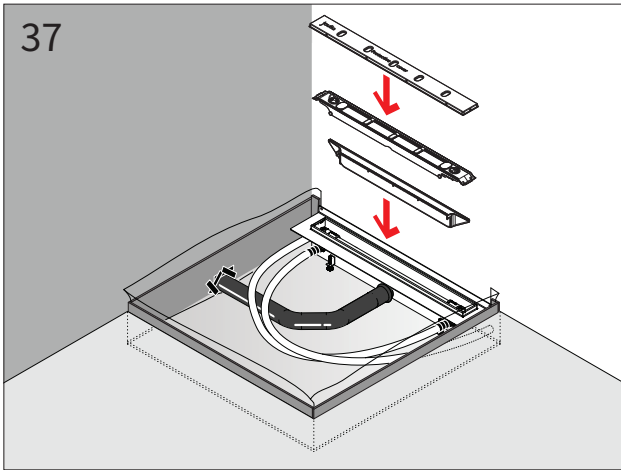
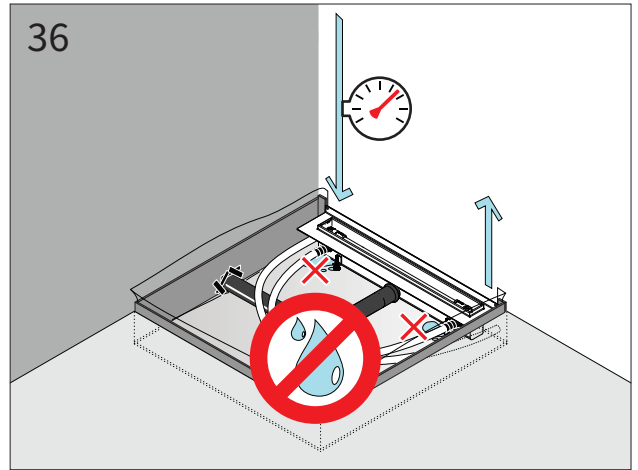
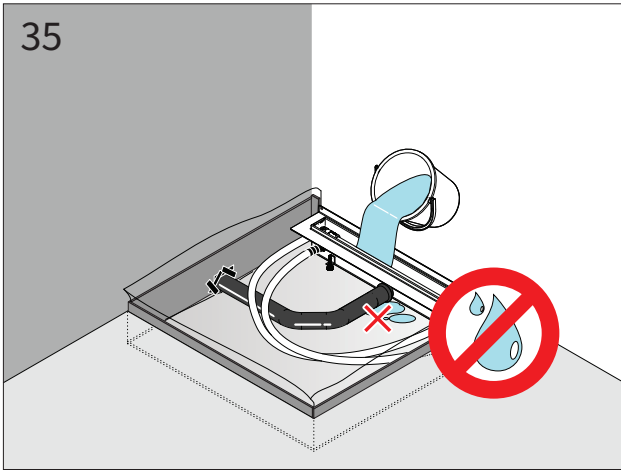
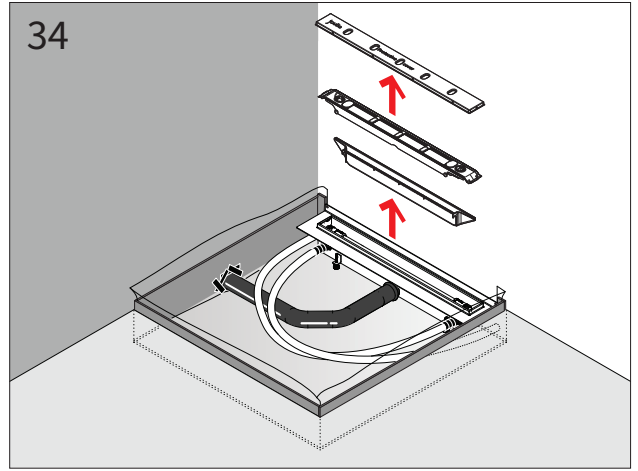
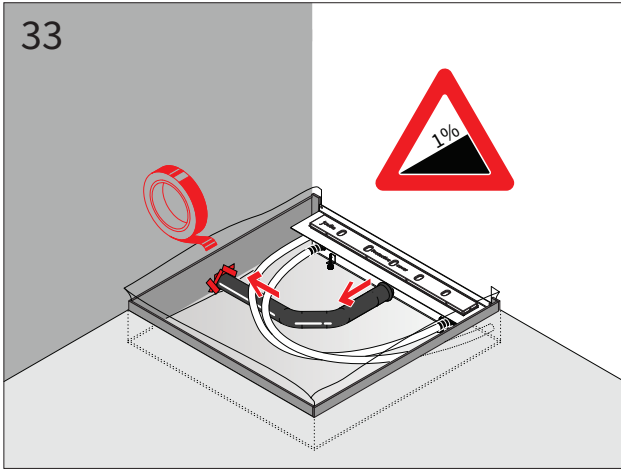

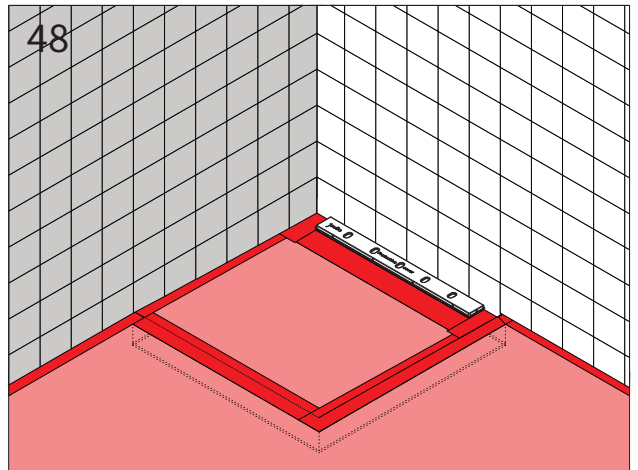
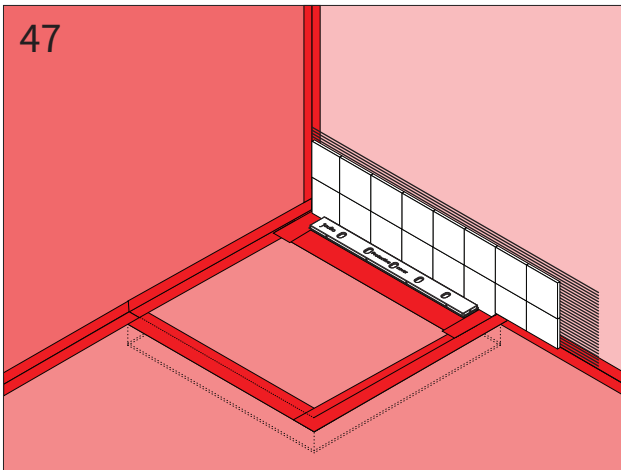
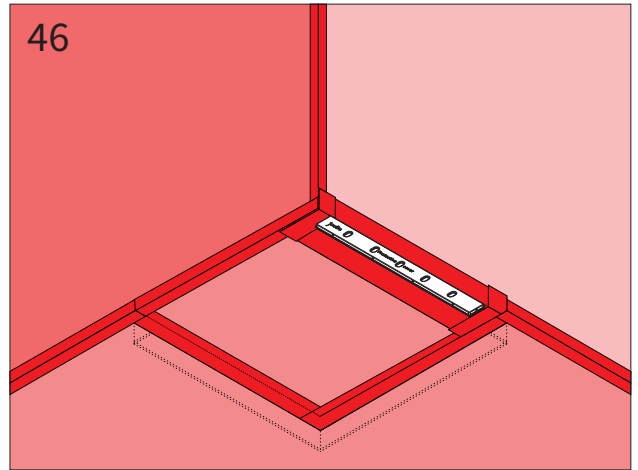
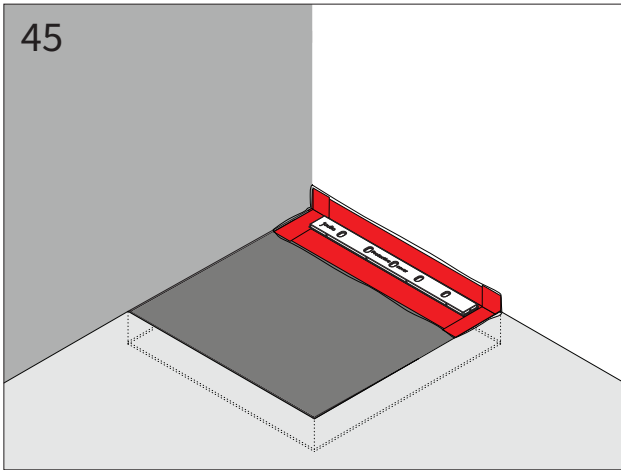
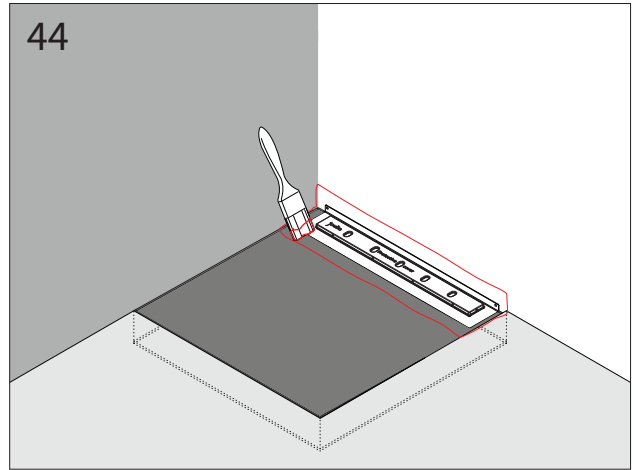
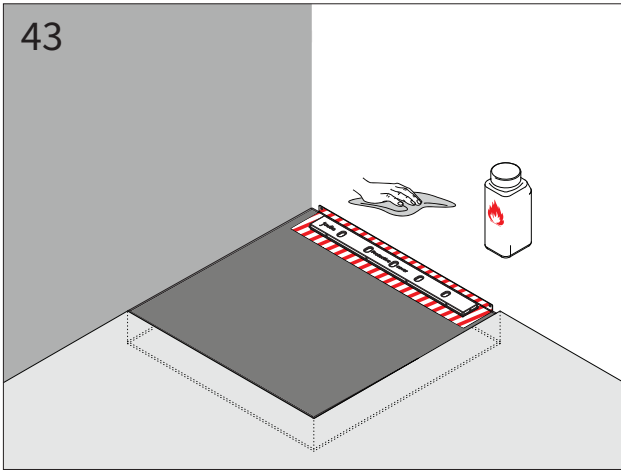
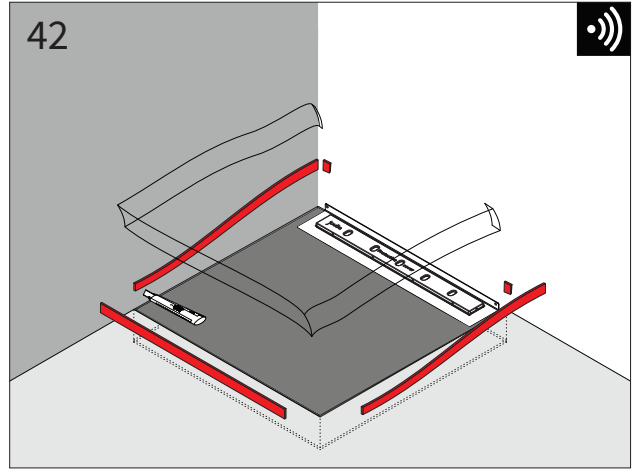
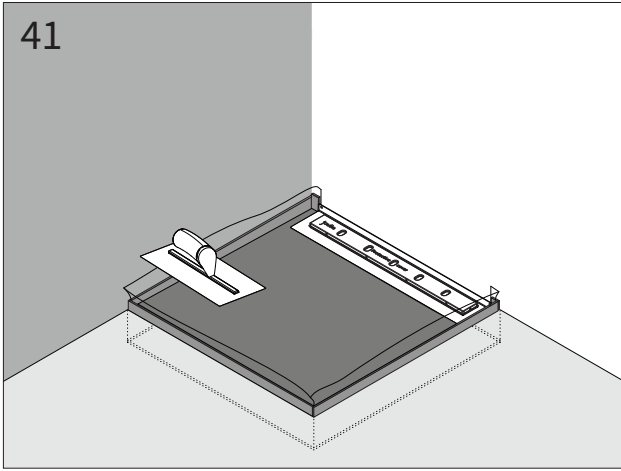



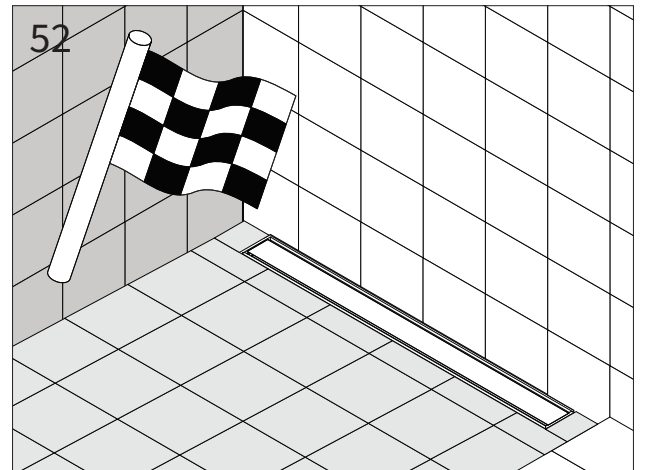
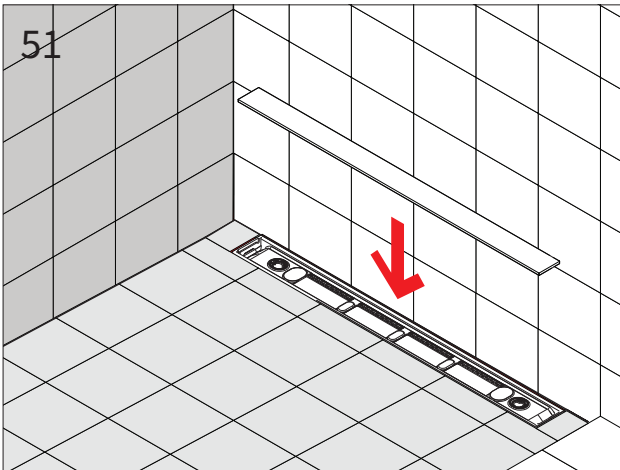
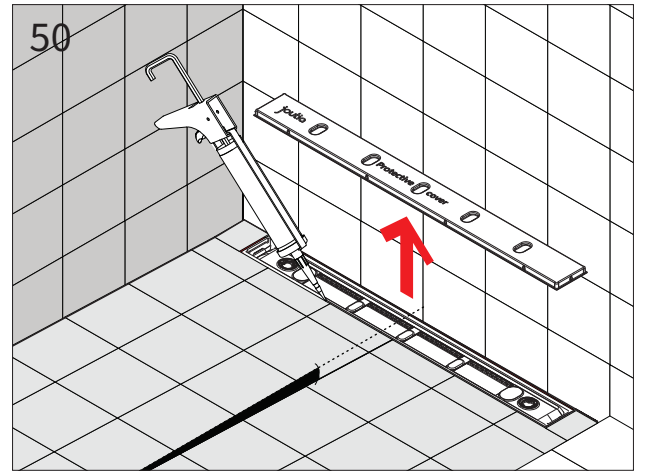
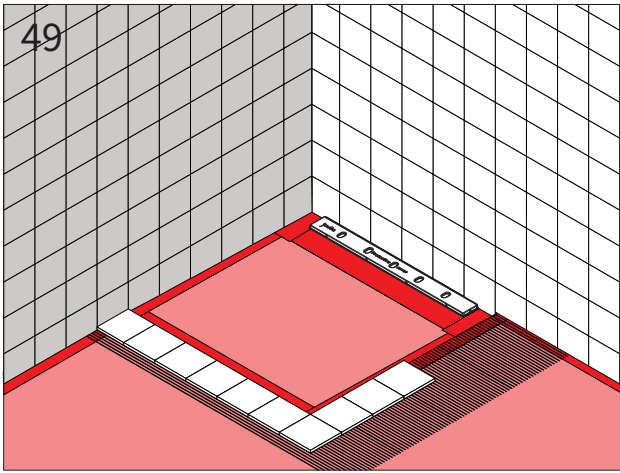

Potentialausgleich  
 Égalisation potentielle  
 Potential equalization  
 Potentiële vereffening

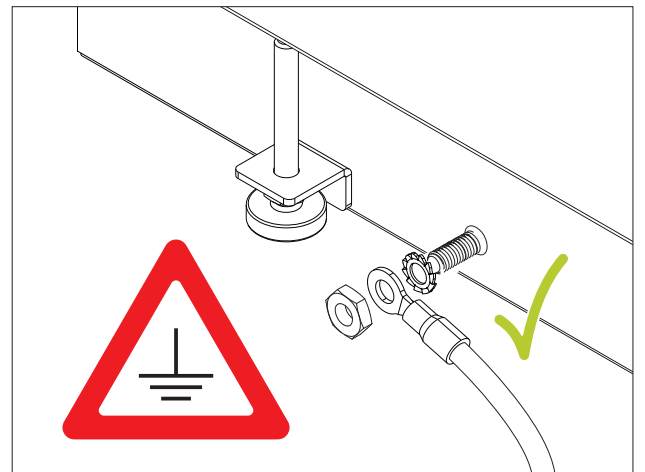



3-73-17-0.1

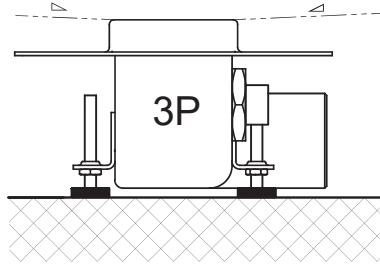

5-73-17-0.1

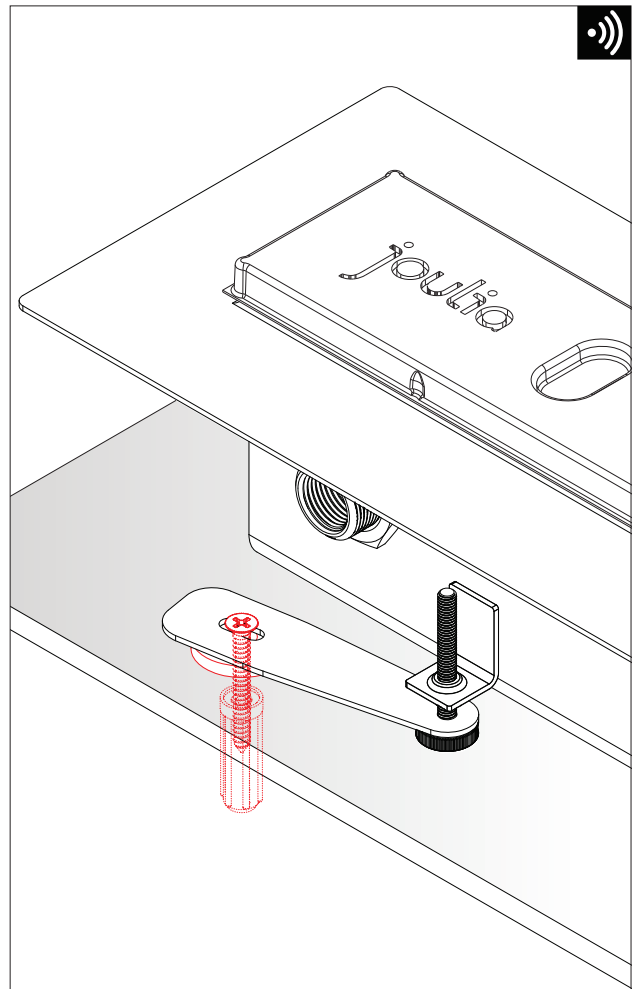
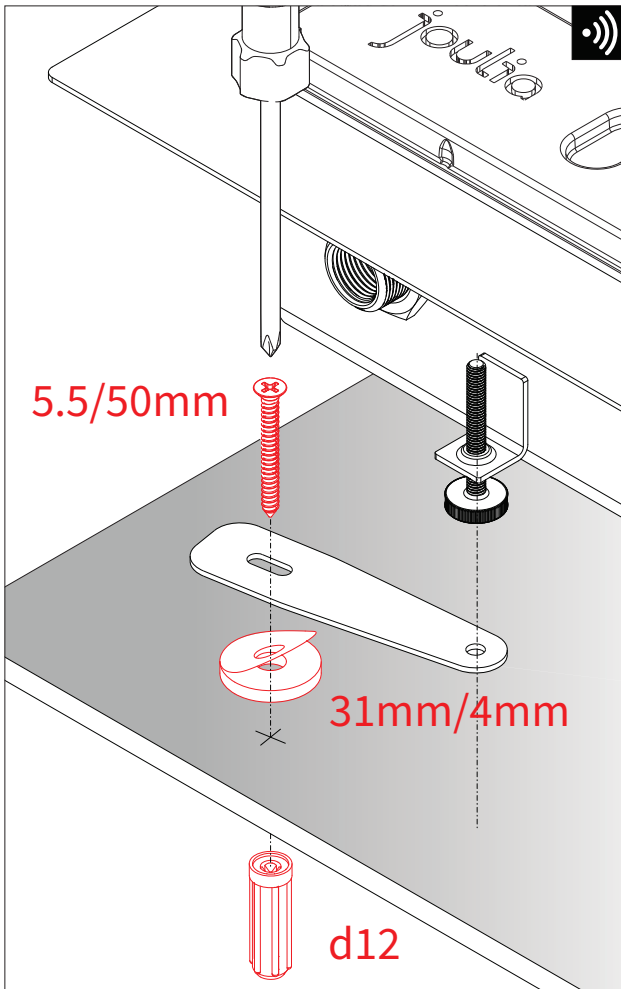
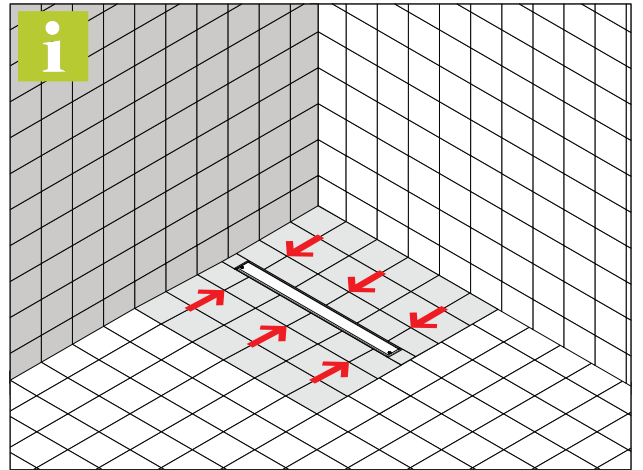
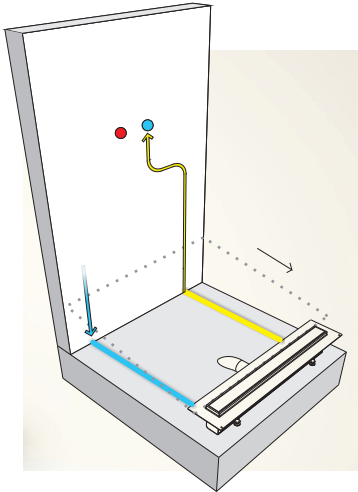
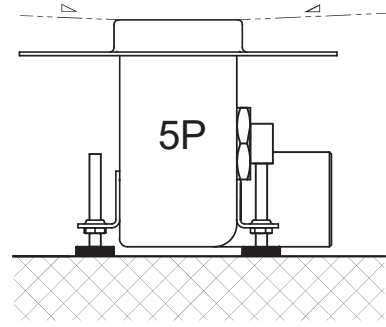



Reinigung  
Entretien  
Cleaning  
Reiniging instructie

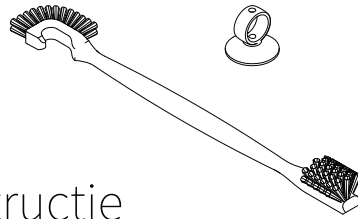

**clean.joulia.com**



Entfernen, reinigen, einsetzen.  
Remove, clean, insert.  
Retirer, nettoyer, insérer.  
Verwijderen, schoonmaken, plaatsen.

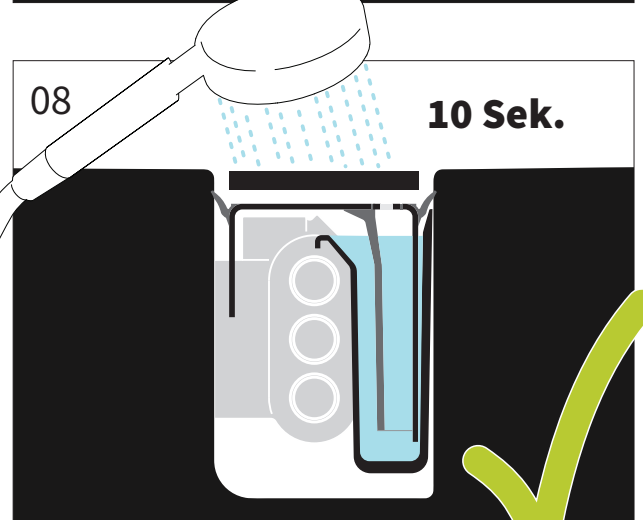
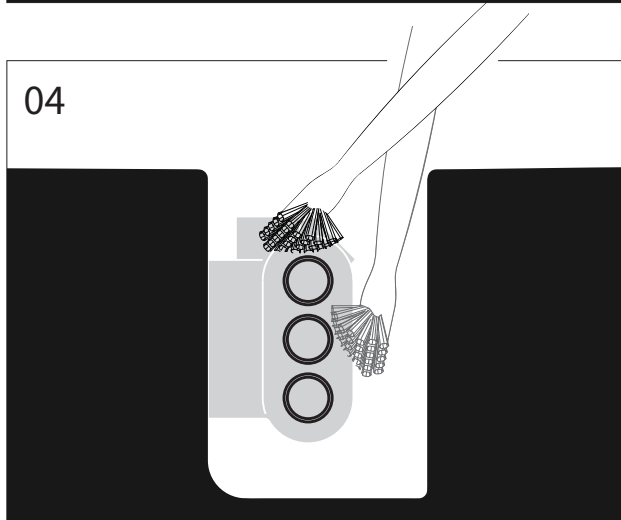
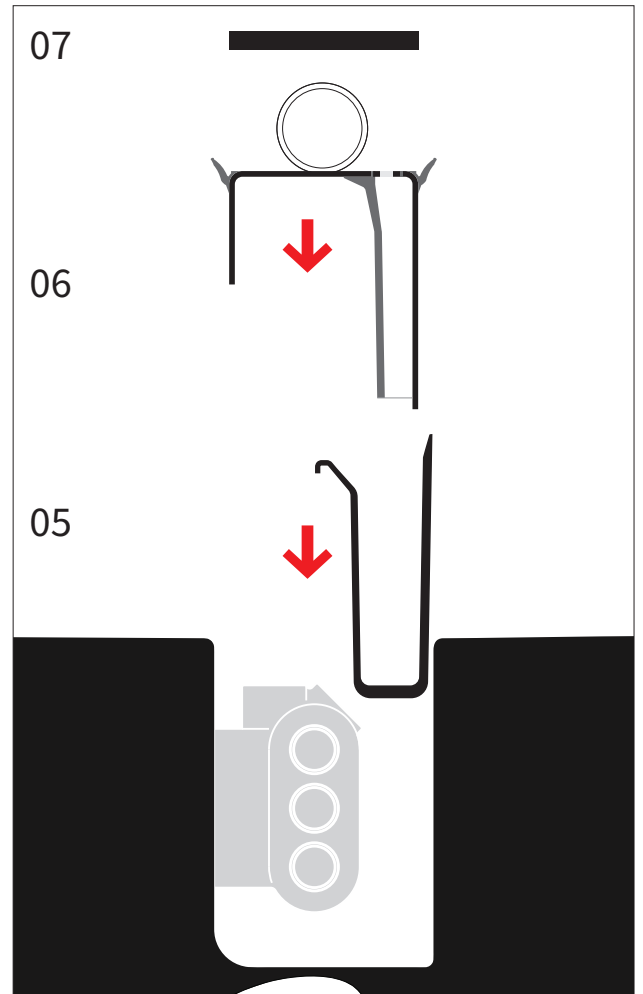
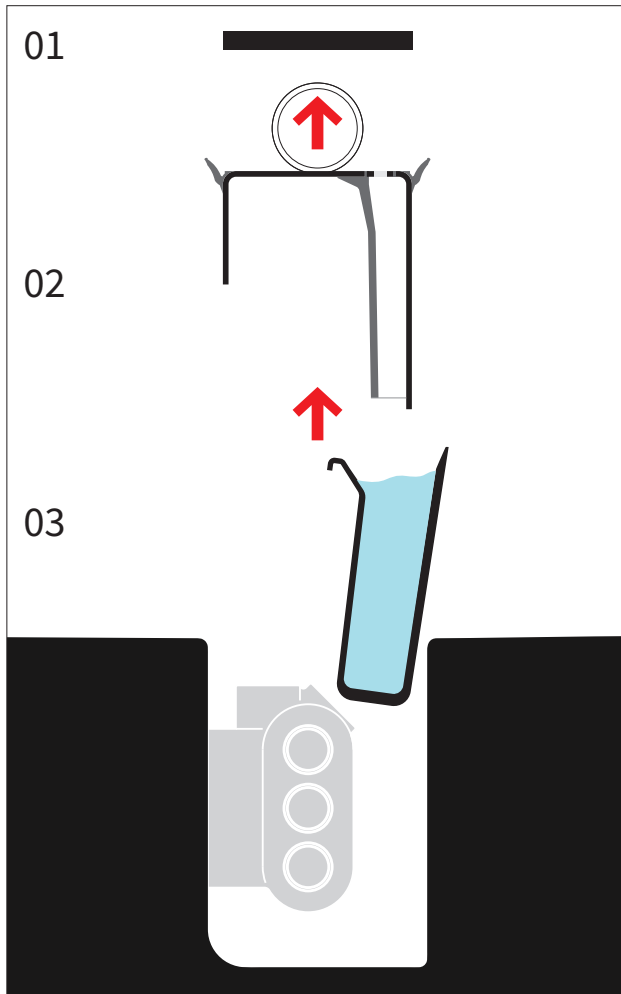



Zwei Optionen  
Deux options  
Two options  
Twee opties

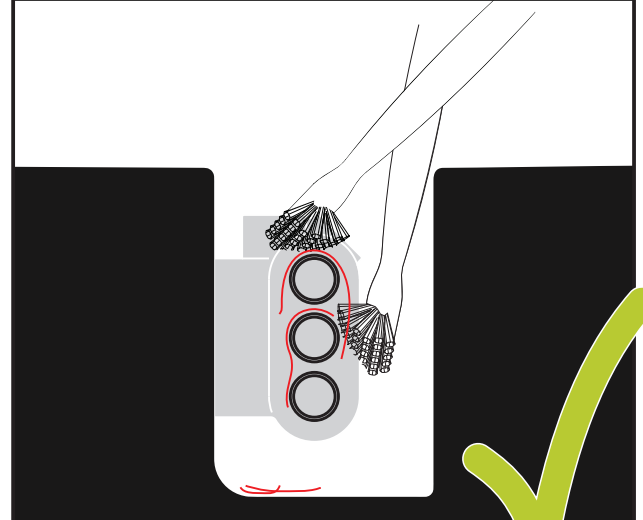
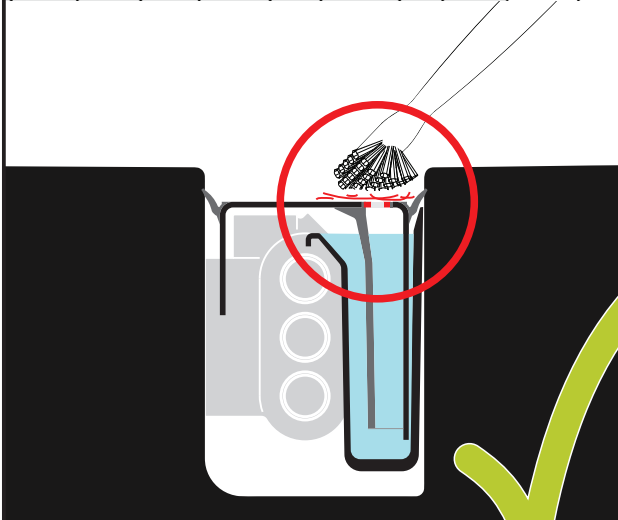
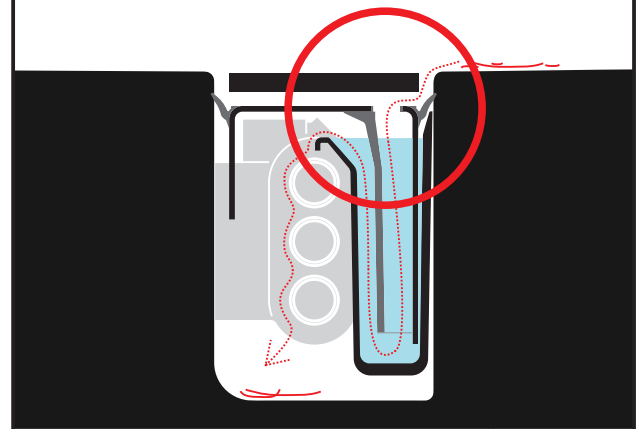
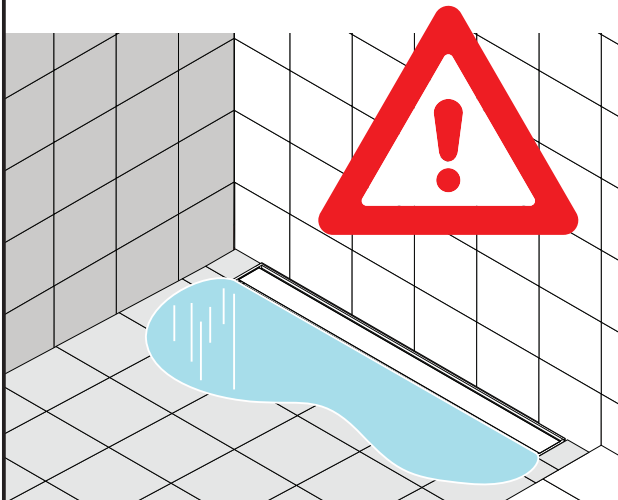
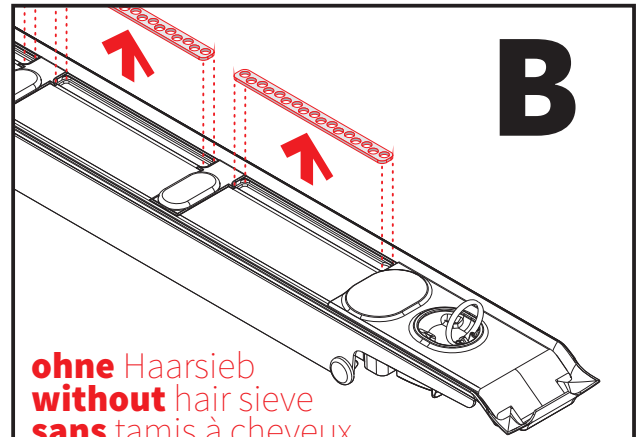
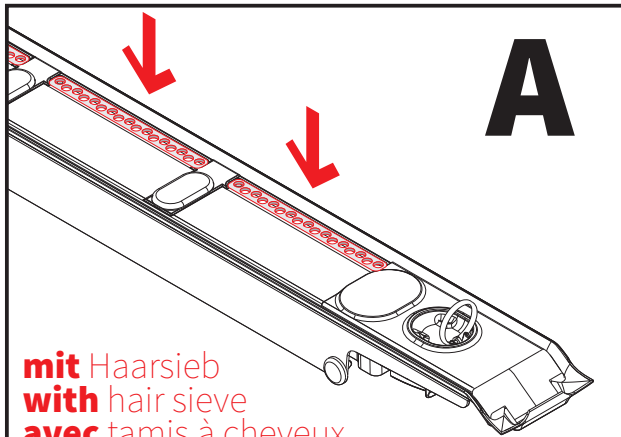
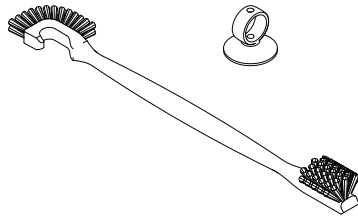



Ausbau Wärmetauscher  
Démontage d'échangeur thermique  
Disassembling of heat exchanger  
Demontage van de warmtewisselaar

01



Wasserzufluss abstellen!  
Couper l'alimentation en eau!  
Cut off water supply!  
De watertoevoer afsluiten!

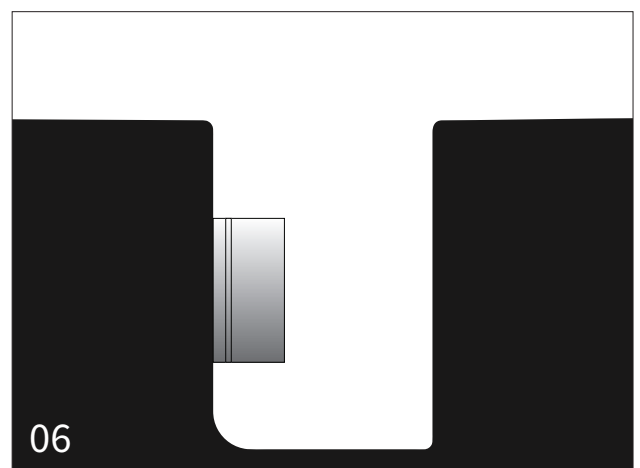
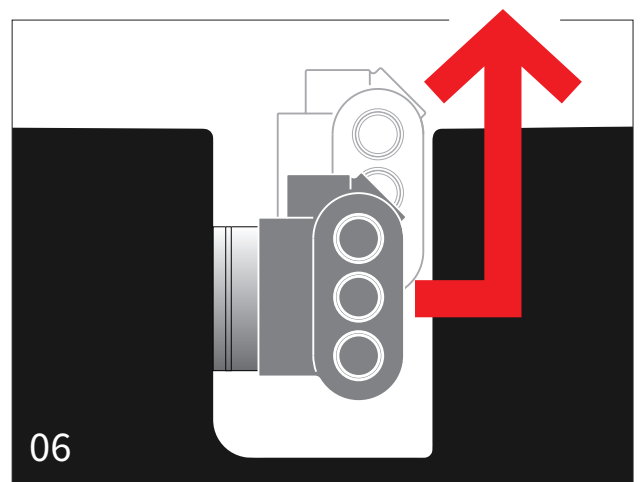
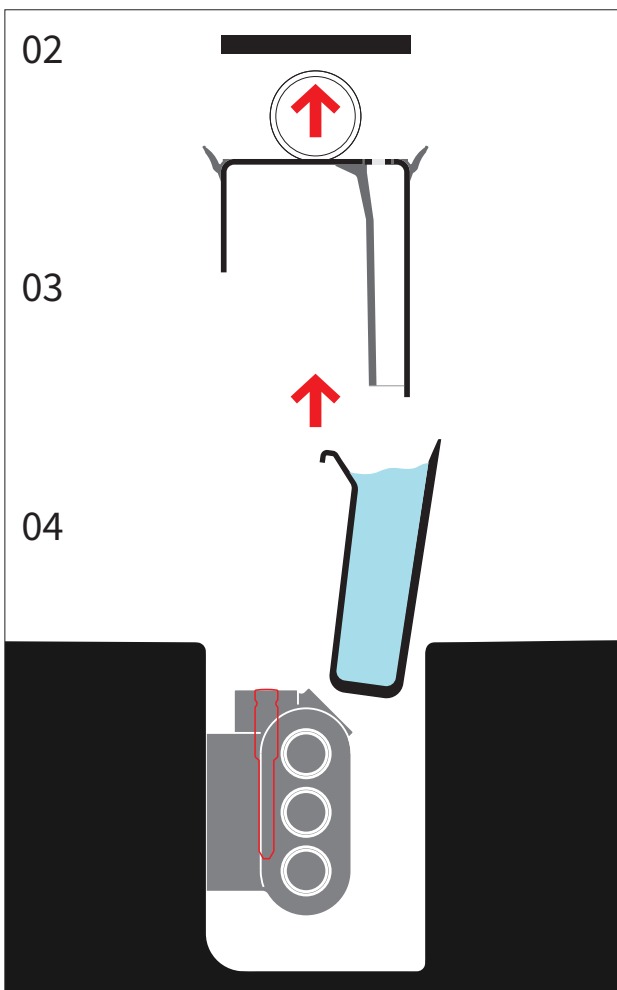
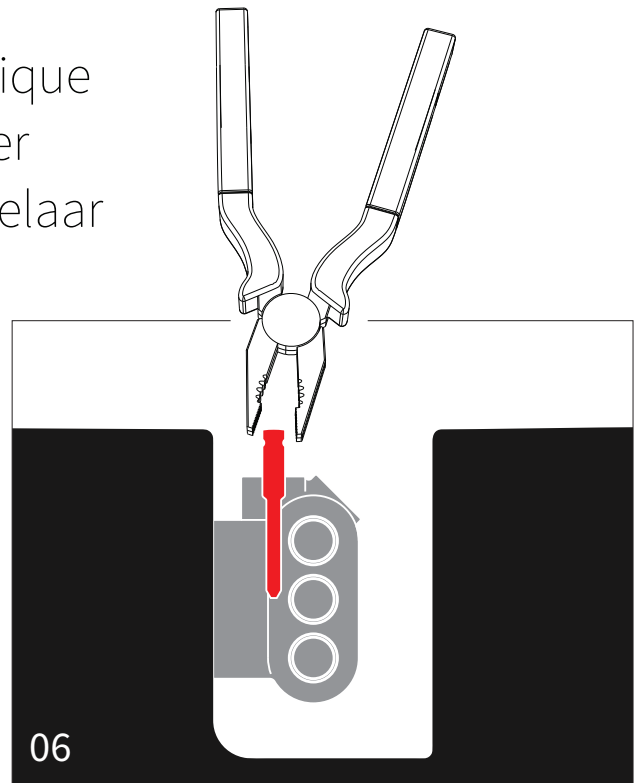



Leckagemelder  
détecteur de fuites  
leakage detector  
lekkagedetector

**buzzer.joulia.com**

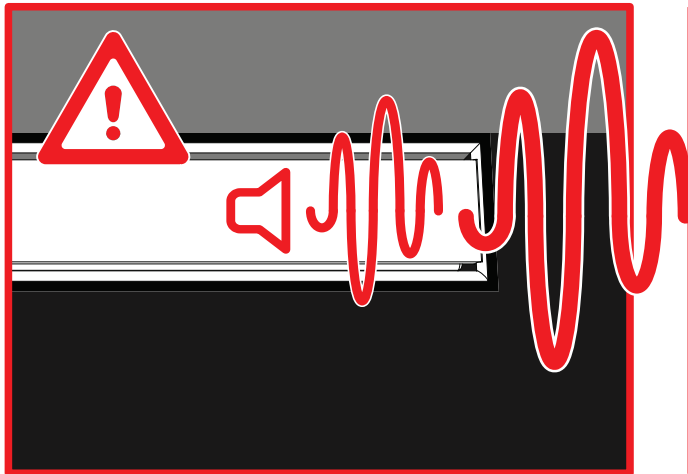

01



Sanitärinstallateur anrufen.  
Appelle le plombier.  
Call your plumber.  
Bel de loodgieter.

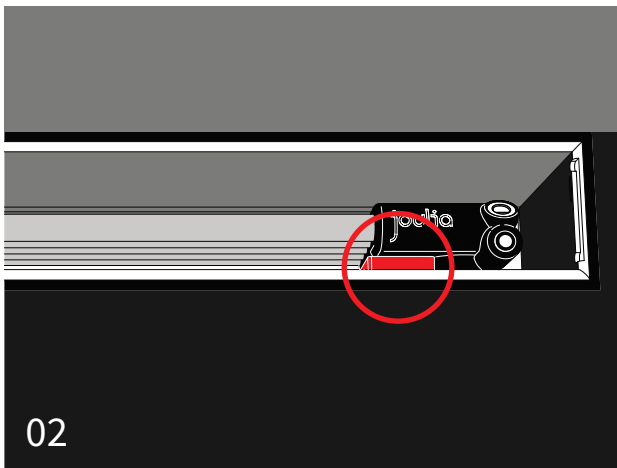



02



03

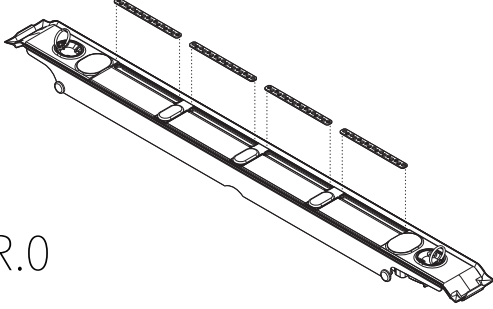
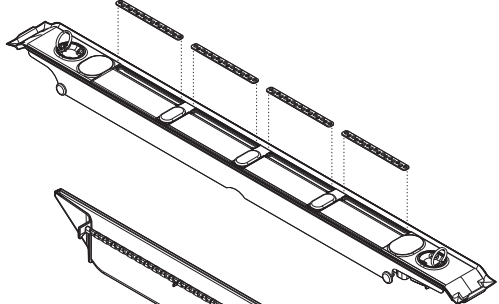
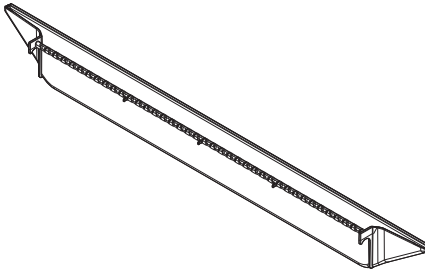
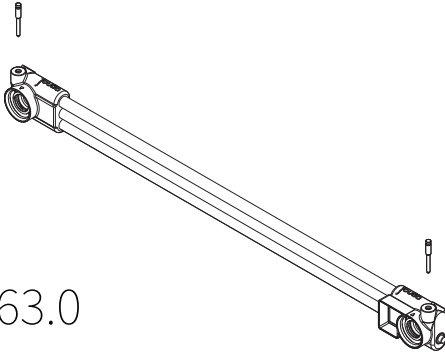
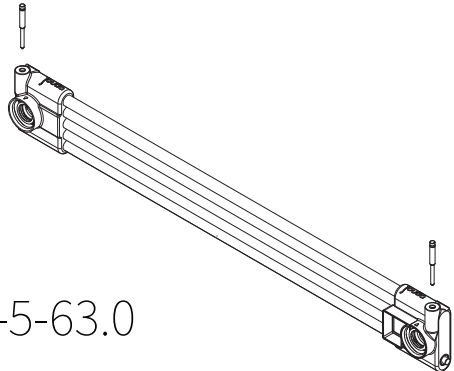

Ersatzteile  
Pièces de rechange  
Spare parts  
Vervangingsonderdelen

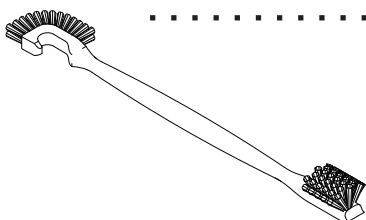
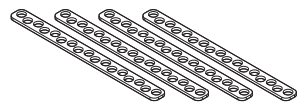
 <p>TR.0</p>	 <p>DT-63.0</p>
 <p>DI.0</p>	
 <p>WT-3-63.0</p>	 <p>WT-5-63.0</p>
 <p>SN.0</p>	 <p>BUZ.0</p>
 <p>RB.0</p>	 <p>HS.0</p>

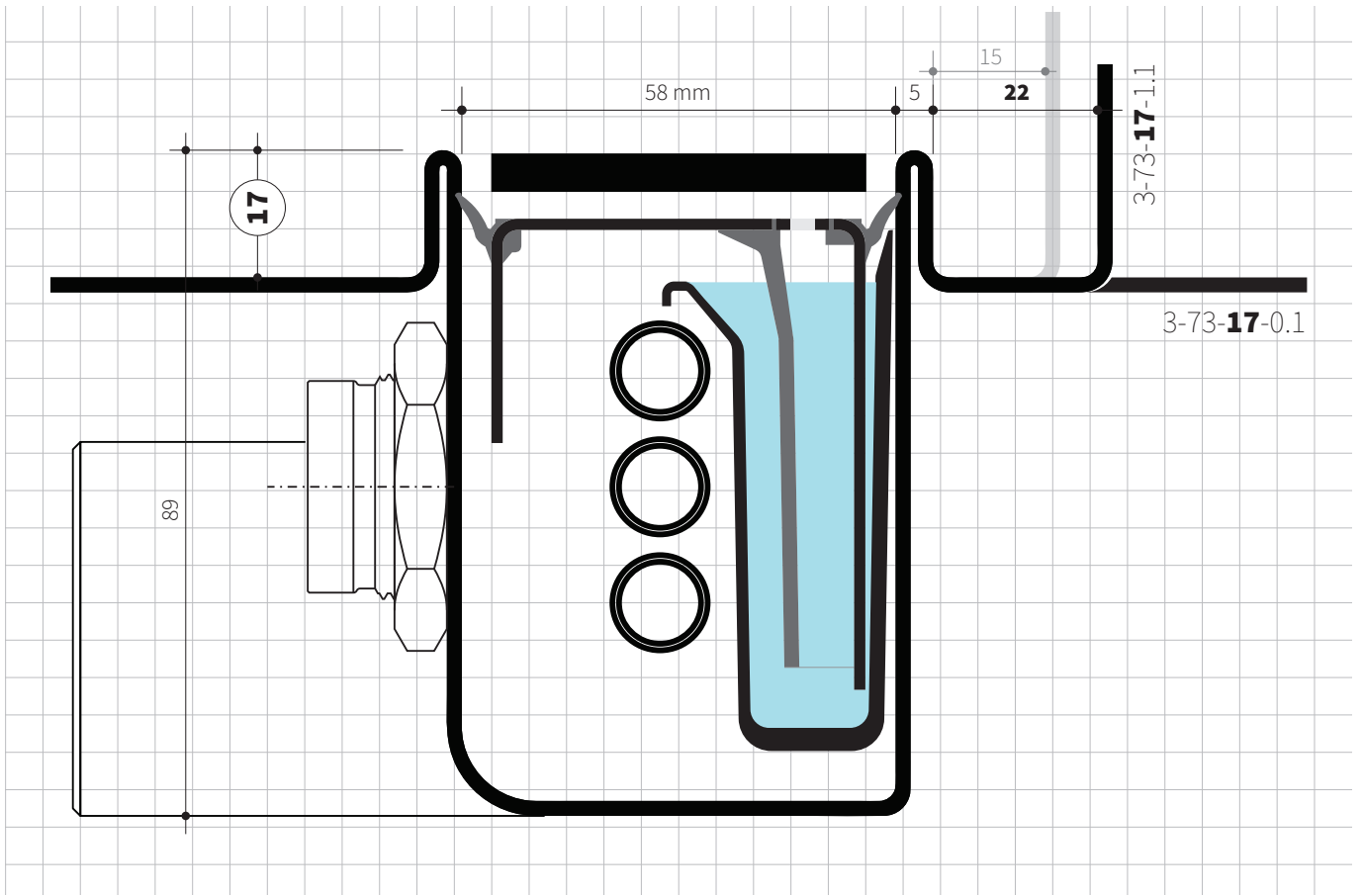

5mm/5mm

